



POMPE ROTOMECC

RS 1013-10.2

DN 100 2900 rpm

Pompe sommergibili con girante arretrata a vortice
Submersible pumps with vortex impeller
Electropompes submersibles avec roue vortex

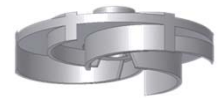

N°	CURVA - Curve - Courbe	POMPA Pump Pompe	GIRI/Min - RPM. - Tours/min.	POTENZA RESA NOMINALE Rated power Puissance nominale (P ₂)	ASSORBIMENTO NOMINALE Rated current Intensité nominale 400 V.	FATTORE DI POTENZA Power factor Facteur de puissance	TENSIONE - Voltage	CAVO - Cable	SONDE TERMICHE Thermal control Thermosondes	SENSORE INFILTRAZIONE Moisture sensor Detecteur de infiltration	PESO - Weight - Poids	INSTALLAZIONE - Installation	F	M
1	RS 1013/2 - 1180							H07RNF 10mt.						
2	RS 1013/2 - 1190	2900	13,5	26,5	0,82	400/700 V.	(1) 10G2,5	●	○	175	○	○		
3	RS 1013/2 - 1200													

● Di serie - Standard

■ Con protezioni - With protections - Avec sondes

○ A richiesta - On request - A la demande



PASSAGGIO LIBERO
Free passage - Section de passage
75 mm

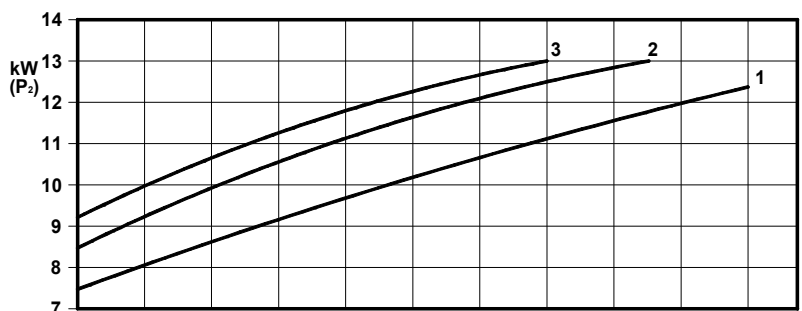
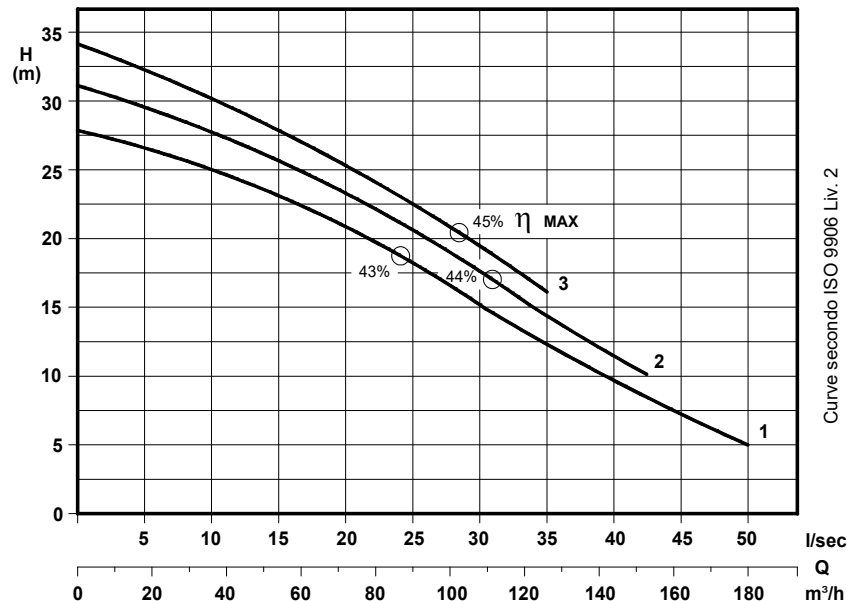

P₂ - Potenza resa - Shaft power - Puissance sur arbre

COSTRUZIONE - Materials - Matériaux	
Fusioni principali Principal parts Parts principal	Ghisa Cast iron - Fonte GG 25
Girante Impeller - Roue	Ghisa Cast iron - Fonte GG 25
Albero - Shaft - Arbre	AISI 420
Viteria - Screws - Vis	AISI 304
Motore - Motor - Moteur	IP68
Classe isolamento - Insulating class	F

TENUTE MECCANICHE - Mechanical seals - Garniture mécanique

Doppia tenuta meccanica in bagno d'olio - Double mechanical seals in oil bath - Double garniture mécanique en chambre d'huile
 Superiore - Upper - Supérieur : Grafite/Allumina - Graphite/Alumina
 Inferiore - Lower - Inferieur : Carburo di silicio - Silicon carbide

Max profondità di installazione - Max installation depth
 Max profondeur d'installation = 20m.

INSTALLAZIONE MOBILE - *Mobile installation - Installation portable*

M

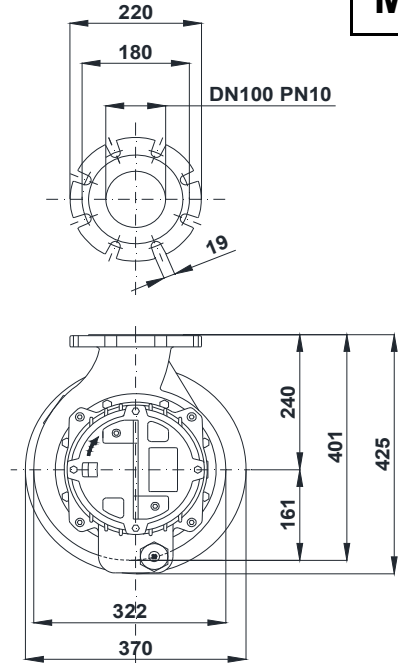
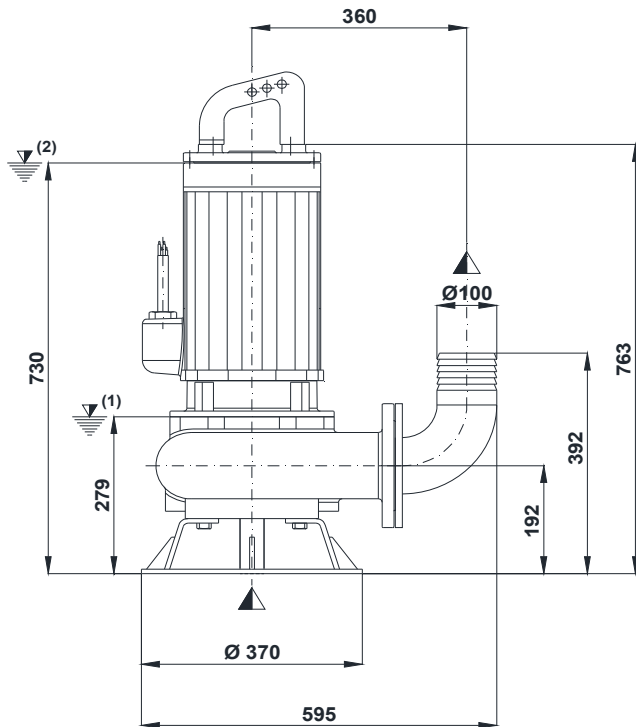

(1) Livello minimo di arresto per funzionamento automatico.
 Lowest shut-of level for automatic control.
 Point d'arrêt plus bas pour service automatiques.

INSTALLAZIONE FISSA - *Fixed installation - Installation fixe*

(2) Sommergenza minima per funzionamento continuo.
 Minimum covering level for continuous service.
 Submersion minimal pour service continu.

Staffa fissaggio tubi guida
 Upper guide rails bracket
 Etrier supérieur pour tube de guidage

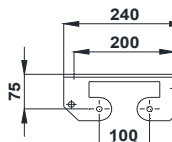

Tubo Guida
 Pipe guide
 Tube de guidage

DISPOSITIVO DI ACCOPIAMENTO -
 Discharge connection bracket
 Dispositif d'accouplement

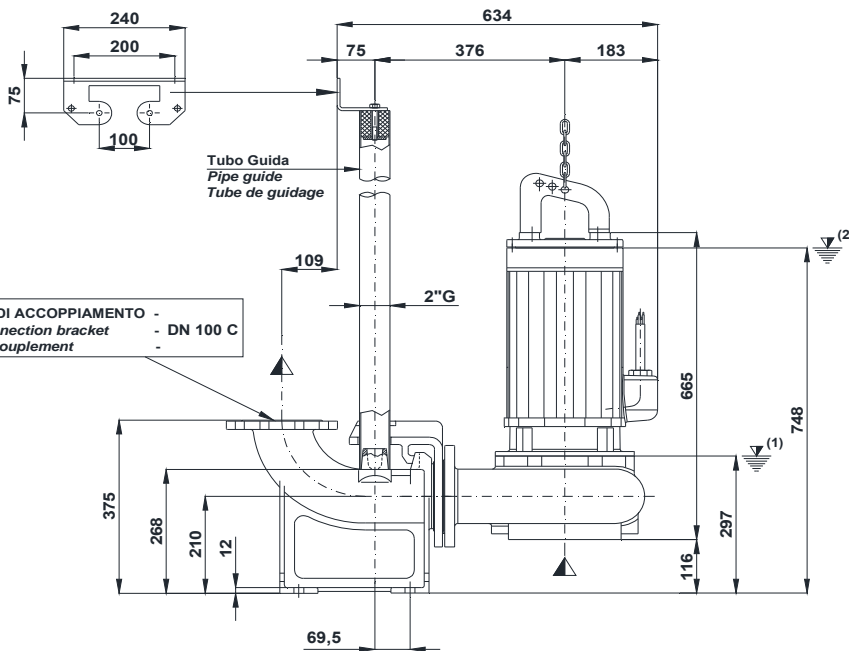

F

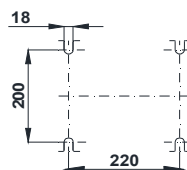
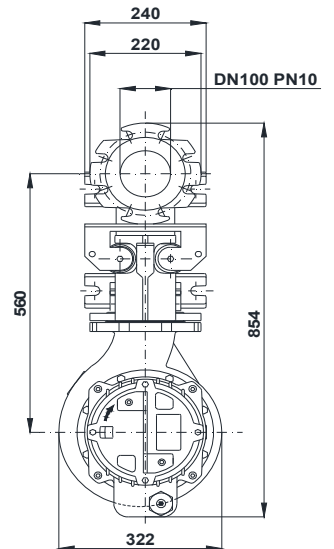



POMPE ROTOMECC

RS 1022-20.2

DN 100

2900 rpm

Pompe sommergibili con girante arretrata a vortice
Submersible pumps with vortex impeller
Electropompes submersibles avec roue vortex

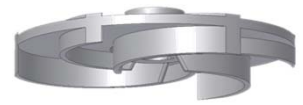

N°	CURVA - Curve - Courbe	POMPA Pump Pompe	GIRI /Min - RPM. - Tours/min.	POTENZA RESA NOMINALE Rated power Puissance nominale (Pn)	ASSORBIMENTO NOMINALE Rated current Intensité nominale 400 V.	FATTORE DI POTENZA Power factor Facteur de puissance	TENSIONE - Voltage	CAVO - Cable	SONDE TERMICHE Thermal control Thermosondes	SENSORE INFILTRAZIONE Moisture sensor Detecteur de infiltration	PESO - Weight - Poids	INSTALLAZIONE - Installation F = FISSA - Fixed - Fixe M = MOBILE - Mobile - Portable
1	RS 1022/2 - 2190	2900	22	45	0,89	3~ 50 Hz	400/700 V.	H07RNF 10mt. (1) 10G2,5	●	○	230	○
2	RS 1022/2 - 2200											
3	RS 1022/2 - 2210											
4	RS 1022/2 - 2220											
5	RS 1022/2 - 2230											

● Di serie - Standard

○ A richiesta - On request - A la demande



PASSAGGIO LIBERO

Free passage - Section de passage
85 mm

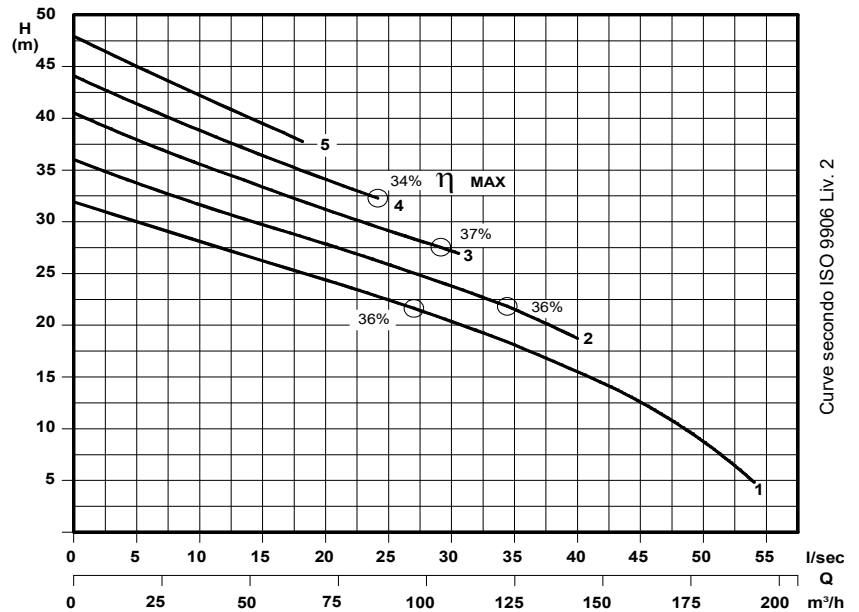

Curve secondo ISO 9906 Liv. 2

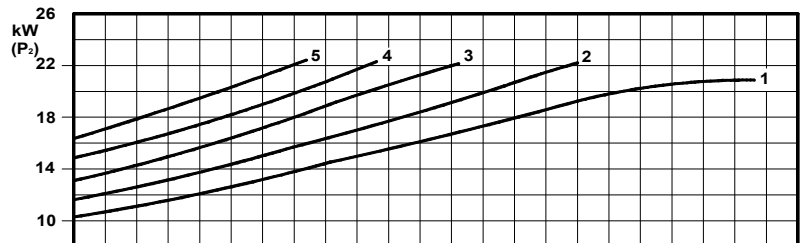

P₂ - Potenza resa - Shaft power - Puissance sur arbre

COSTRUZIONE - Materials - Matériaux

Fusioni principali Principal parts Parts principal	Ghisa Cast iron - Fonte GG 25
Girante Impeller - Roue	Ghisa Cast iron - Fonte GG 25
Albero - Shaft - Arbre	AISI 420
Viteria - Screws - Vis	AISI 304
Motore - Motor - Moteur	IP68
Classe isolamento - Insulating class	F

TENUTE MECCANICHE - Mechanical seals - Garniture mécanique

Doppia tenuta meccanica in bagno d'olio - Double mechanical seals in oil bath - Double garniture mécanique en chambre d'huile
 Superiore - Upper - Supérieur : Grafite/Allumina - Graphite/Alumina
 Inferiore - Lower - Inferieur : Carburo di silicio - Silicon carbide
 Max profondità di installazione - Max installation depth
 Max profondità d'installazione = 20m.

INSTALLAZIONE MOBILE - *Mobile installation - Installation portable*

M

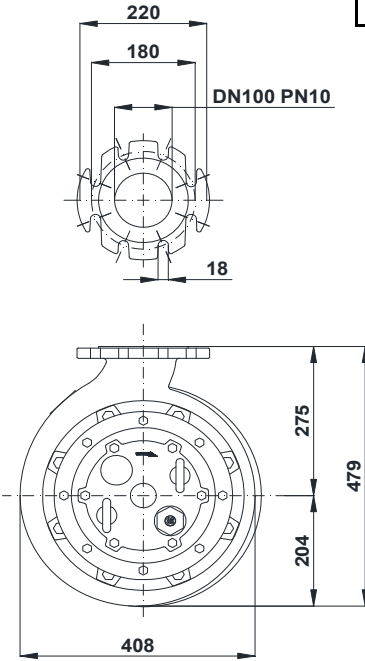
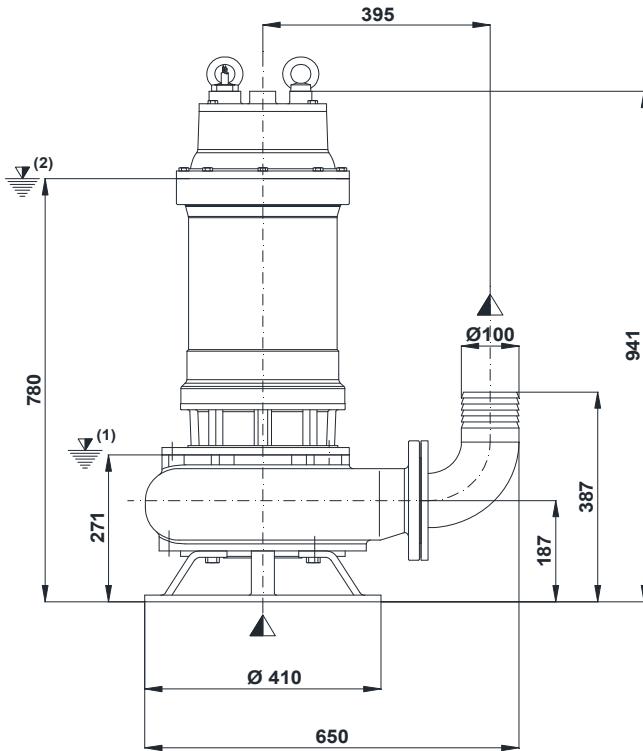

(1) Livello minimo di arresto per funzionamento automatico.
 Lowest shut-of level for automatic control.
 Point d'arrêt plus bas pour service automatiques.

INSTALLAZIONE FISSA - *Fixed installation - Installation fixe*

(2) Sommergenza minima per funzionamento continuo.
 Minimum covering level for continuous service.
 Submersion minimal pour service continu.

F

