



POMPE ROTOMECC

KB 80/4-220.1

DN 80

Giri/1' - r.p.m.

1450

Elettropompe centrifughe ad asse orizzontale con girante bicanale aperta e diffusore autopulente
Centrifugal horizontal pumps with channel impeller and self cleaning diffuser
Pompes à axe horizontal avec roue à canaux et anneau autonettoyant

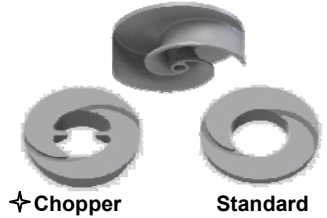
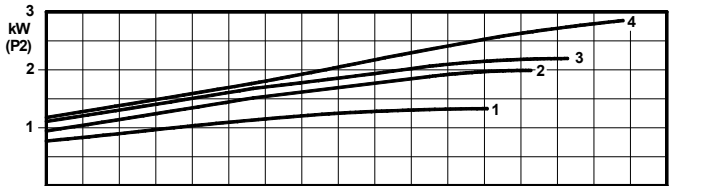
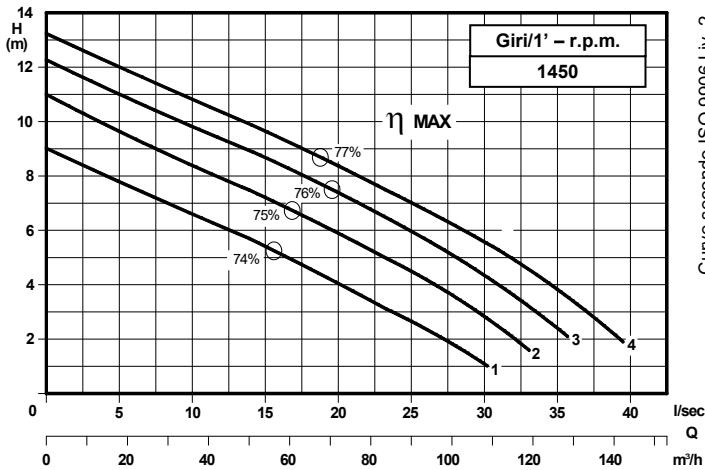

Grandezza - Size - Group 80/220

Curva Curve Courbe N°	Pompa Pump Pompe	DN	Potenza motore Motor power P2 (Kw)	Giri/1' r.p.m.
1	KB 80-165 A1 S1	80	1,5	1450
2	KB 80-180 A1 S1		2,2	
3	KB 80-185 A1 S1		3	
4	KB 80-190 A1 S1			

P2 - Potenza resa - Shaft power - Puissance sur arbre

COSTRUZIONE - Materials - Matériaux

Fusioni principali - Principal parts - Parts principal	Ghisa - Cast iron - Fonte - GG 25
Girante - Impeller - Roue	Ghisa - Cast iron - Fonte - GS 500
Diffusore - Diffuser - Anneau	Ghisa - Cast iron - Fonte - GS 500
Albero - Shaft - Arbre	AISI 420
Viteria - Screws - Vis	AISI 304

TENUTE MECCANICHE - Mechanical seals - Garniture mécanique

Doppia tenuta meccanica in bagno d'olio - Double mechanical seals in oil bath - Double garniture mécanique en chambre d'huile
Tenuta lato motore / tenuta lato liquido : carburo di silicio
Motor side / liquid side mechanical seal : silicon carbide
Garniture mécanique côté du moteur / côté liquide : carbure de silicium

CARATTERISTICHE TECNICHE - Technical Features - Caractéristiques Techniques

Max. temperatura liquido - Max. liquid temp. - Max. temperature du liquide : 60°C
pH Liquido pompato - pH pumped liquid - pH du liquide pompé : 6 - 10

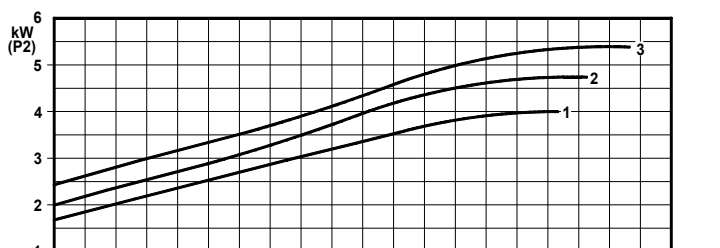
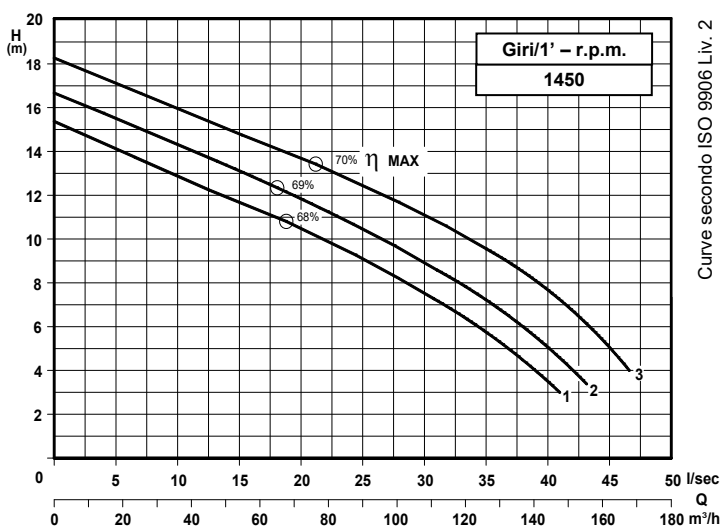

Grandezza - Size - Group 80/220

Curva Curve Courbe N°	Pompa Pump Pompe	DN	Potenza motore Motor power P2 (Kw)	Giri/1' r.p.m.
1	KB 80-205 A1 S1	80	4	1450
2	KB 80-210 A2 S1		5,5	
3	KB 80-219 A2 S1			

P2 - Potenza resa - Shaft power - Puissance sur arbre

✦ Versione chopper con diffusore a taglienti e girante induriti
Chopper version with cutting diffuser and impeller hardened
Version chopper avec anneau tranchant et roue durci

DIMENSIONI DI INGOMBRO – Dimensions

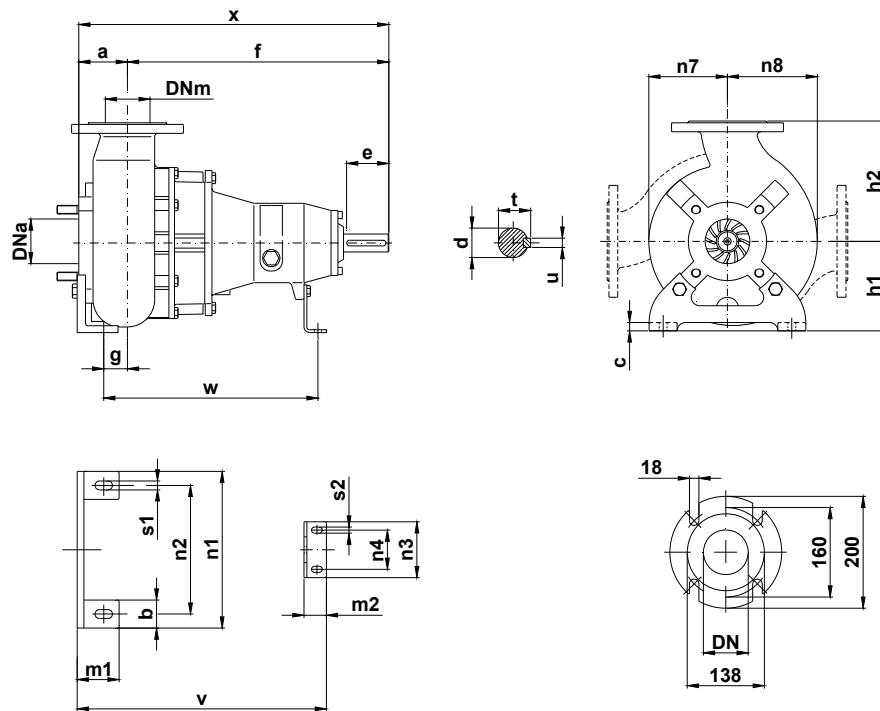

Pompa Pump Pompe	DNa DNm	a	b	c	d	e	f	g	h1	h2	m1	m2	n1	n2	n3	n4	n7	n8	s1	s2	t	u	v	w	x	Peso Weight Poids
KB 80 / .. A1S1 KB 80 / .. A2S1	80	90	50	12	32	80	467	49	180	215	75	45	280	230	120	90	140	160	16	11	35	10	456	392	557	68

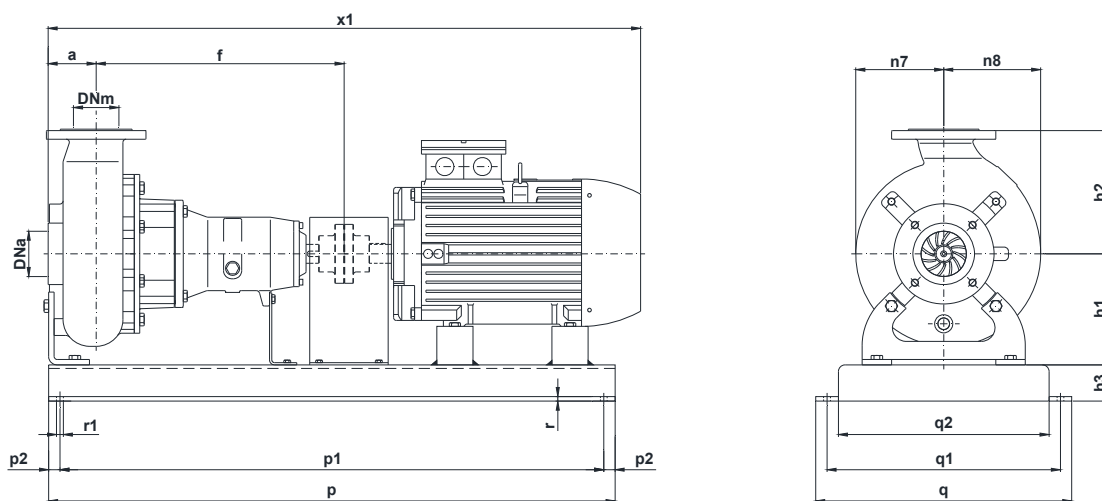

Pompa Pump Pompe	kW	Giri/1' r.p.m.	Motore Motor - Moteur MEC	h3	p	p1	p2	q	q1	q2	r	r1	x1	Peso Weight Poids
KB 80-165 A1 S1	1,5	1450	100	70	1000	800	100	500	420	360	10	16	945	134
KB 80-180 A1 S1	2,2													136
KB 80-185 A1 S1	3													146
KB 80-190 A1 S1	4		112	90	1200	1000	100	560	510	440	12	18	1075	219
KB 80-205 A1 S1	5,5													
KB 80-210 A1 S1														
KB 80-219 A2 S1														

KB 80-220.1.19W

Con riserva di variazioni tecniche e costruttive senza preavviso.

With reserve of technical and constructive variations without warning. Avec réserve de variations techniques et constructives sans préavis

POMPE ROTOMECC srl - 20063 CERNUSCO SUL NAVIGLIO (MI) - ITALY - Via Ponchielli, 1

Tel. +39.02.9211.0205 - +39.02.9233.0399 Fax 02 9211.0630 Sito Internet: www.pomperotomec.it E-mail: sales@pomperotomec.it



POMPE ROTOMECC

KB 80/4-280.1

DN 80

Giri/1' - r.p.m. 1450

Elettropompe centrifughe ad asse orizzontale con girante bicanale aperta e diffusore autopulente
Centrifugal horizontal pumps with channel impeller and self cleaning diffuser
Pompes à axe horizontal avec roue à canaux et anneau autonettoyant

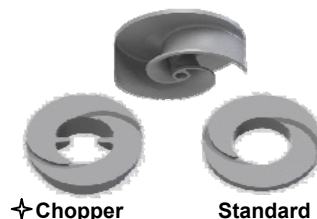
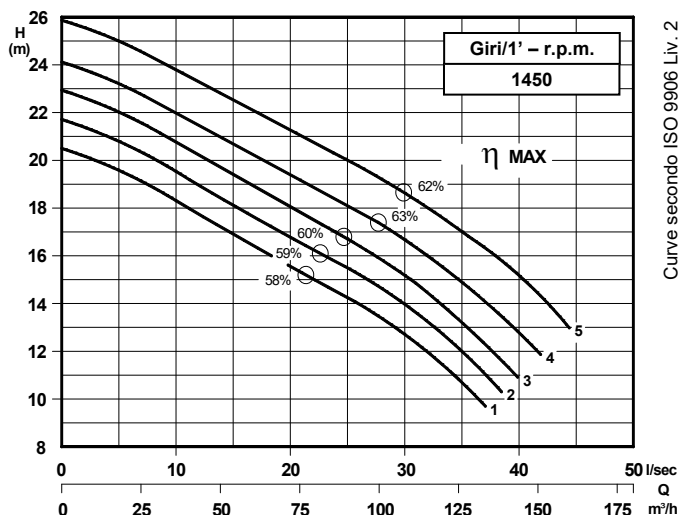

Grandezza - Size - Group 80/280

Curva Curve Courbe N°	Pompa Pump Pompe	DN	Potenza motore Motor power Puissance du moteur P2 (Kw)	Giri/1' r.p.m.
1	KB 80-235 A3 S2	80	7,5	1450
2	KB 80-240 A3 S2			
3	KB 80-245 A3 S2		11	
4	KB 80-250 A3 S2			
5	KB 80-260 A3 S2			

P2 - Potenza resa - Shaft power - Puissance sur arbre

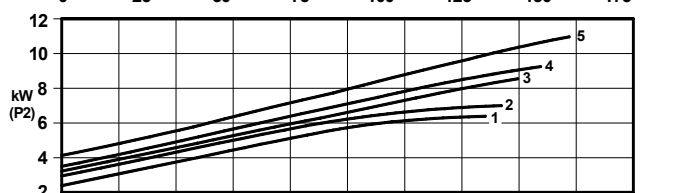

COSTRUZIONE - Materials - Matériaux	
Fusioni principali - Principal parts - Parts principal	Ghisa - Cast iron - Fonte - GG 25
Girante - Impeller - Roue	Ghisa - Cast iron - Fonte - GS 500
Diffusore - Diffuser - Anneau	Ghisa - Cast iron - Fonte - GS 500
Albero - Shaft - Arbre	AISI 420
Viteria - Screws - Vis	AISI 304

TENUTE MECCANICHE - Mechanical seals - Garniture mécanique
Doppia tenuta meccanica in bagno d'olio - Double mechanical seals in oil bath - Double garniture mécanique en chambre d'huile
Tenuta lato motore / tenuta lato liquido : carburo di silicio Motor side / liquid side mechanical seal : silicon carbide
Garniture mécanique côté du moteur / côté liquide : carbure de silicium

CARATTERISTICHE TECNICHE - Technical Features - Caractéristiques Techniques
Max. temperatura liquido - Max. liquid temp. - Max. température du liquide : 60°C
pH Liquido pompato - pH pumped liquid - pH du liquide pompé : 6 - 10

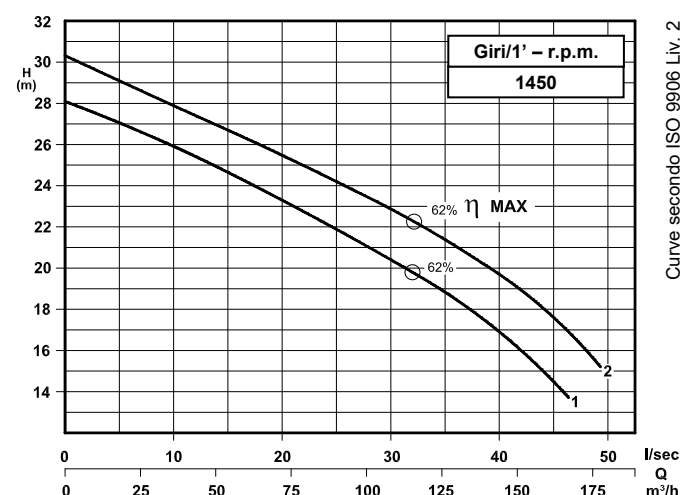

Grandezza - Size - Group 80/280

Curva Curve Courbe N°	Pompa Pump Pompe	DN	Potenza motore Motor power Puissance du moteur P2 (Kw)	Giri/1' r.p.m.
1	KB 80-270 A3 S2	80	15	1450
2	KB 80-279 A3 S2			

P2 - Potenza resa - Shaft power - Puissance sur arbre



✦ Versione chopper con diffusore a taglienti e girante induriti
Chopper version with cutting diffuser and impeller hardened
Version chopper avec anneau tranchant et roue durci

DIMENSIONI DI INGOMBRO – Dimensions

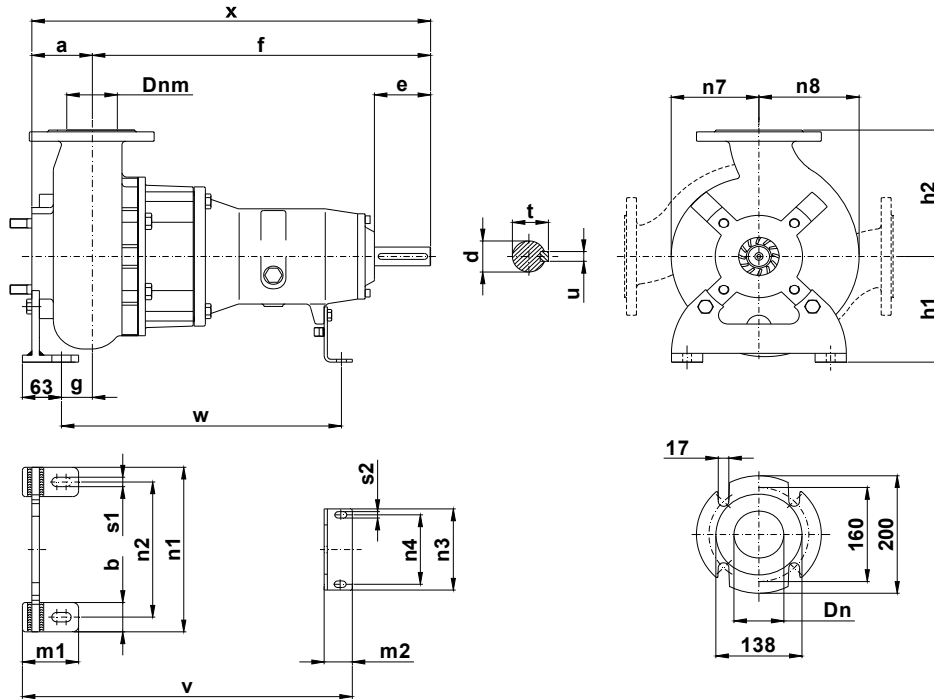

Pompa Pump Pompe	DNa DNm	a	b	c	d	e	f	g	h1	h2	m1	m2	n1	n2	n3	n4	n7	n8	s1	s2	t	u	v	w	x	Peso Weight Poids
KB 80 / .. A3S2	80	90	50	12	42	80	536	49	180	215	90	45	280	230	120	90	140	160	14	11	45	12	528	450	626	97

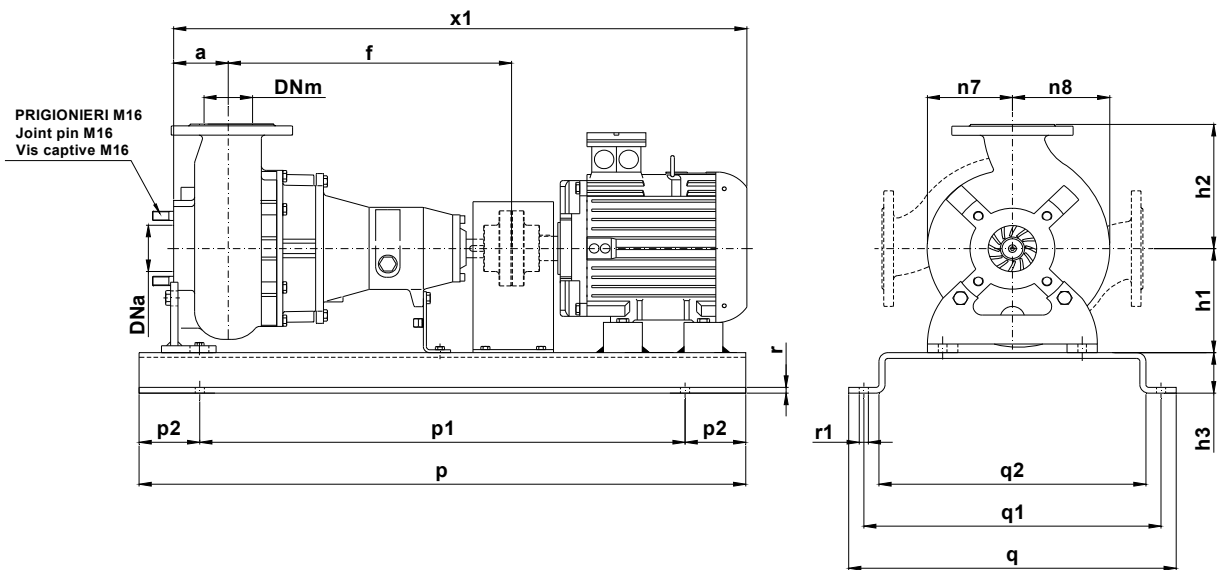

Pompa Pump Pompe	kW	Giri/1' r.p.m.	Motore Motor - Moteur MEC	h3	p	p1	p2	q	q1	q2	r	r1	x1	Peso Weight Poids
KB 80-235 A3 S2	7,5	1450	132	90	1200	1000	-	560	510	440	12	-	1145	258
KB 80-240 A3 S2														
KB 80-245 A3 S2	11	1450	160*	120	1350	1150	100	600	564	-	-	18	1240	308
KB 80-250 A3 S2														
KB 80-260 A3 S2	15	1450	160*	120	1350	1150	100	600	564	-	-	18	1240	318
KB 80-270 A3 S2														
KB 80-279 A3 S2	15	1450	160*	120	1350	1150	100	600	564	-	-	18	1240	318

*Basamento in acciaio profilato saldato – Profiled welded steel base – Profilé de base en acier soudé

KB 80-280.1.19

Con riserva di variazioni tecniche e costruttive senza preavviso.

With reserve of technical and constructive variations without warning. Avec réserve de variations techniques et constructives sans préavis

POMPE ROTOMECC srl - 20063 CERNUSCO SUL NAVIGLIO (MI) - ITALY - Via Ponchielli, 1

Tel. +39.02.9211.0205 - +39.02.9233.0399 Fax 02 9211.0630 Sito Internet: www.pomperotomec.it E-mail: sales@pomperotomec.it



POMPE ROTOMECH

KB 80/2-220.1

DN 80

Giri/1' - r.p.m.
2900

Elettropompe centrifughe ad asse orizzontale con girante bicanale aperta e diffusore autopulente
Centrifugal horizontal pumps with channel impeller and self cleaning diffuser
Pompes à axe horizontal avec roue à canaux et anneau autonettoyant

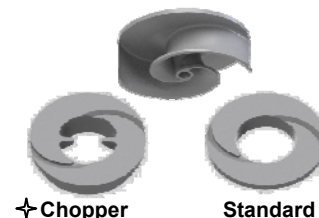
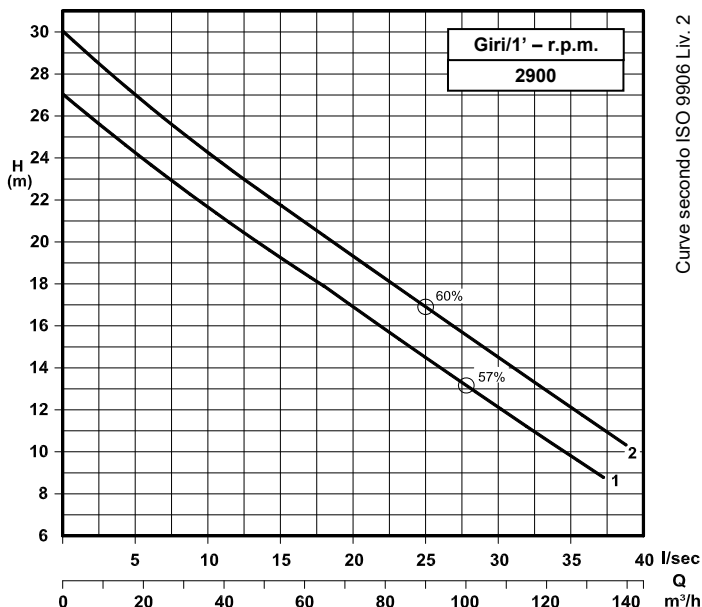

Grandezza - Size - Group 80/220

Curva Curve Courbe N°	Pompa Pump Pompe	DN	Potenza motore Motor power Puissance du moteur P2 (Kw)	Giri/1' r.p.m.
1	KB 80/2-150 A3 S2	80	7,5	2900
2	KB 80/2-158 A3 S2			

P2 - Potenza resa - Shaft power - Puissance sur arbre

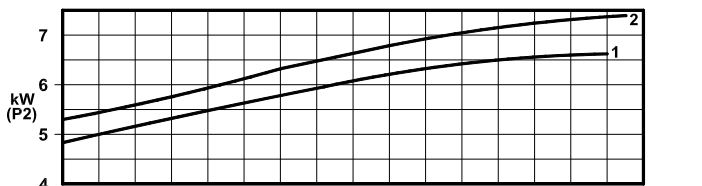

COSTRUZIONE - Materials - Matériaux	
Fusioni principali - Principal parts - Parts principal	Ghisa - Cast iron - Fonte - GG 25
Girante - Impeller - Roue	Ghisa - Cast iron - Fonte - GS 500
Diffusore - Diffuser - Anneau	Ghisa - Cast iron - Fonte - GS 500
Albero - Shaft - Arbre	AISI 420
Viteria - Screws - Vis	AISI 304

TENUTE MECCANICHE - Mechanical seals - Garniture mécanique
Doppia tenuta meccanica in bagno d'olio - Double mechanical seals in oil bath - Double garniture mécanique en chambre d'huile
Tenuta lato motore / tenuta lato liquido : carburo di silicio Motor side / liquid side mechanical seal : silicon carbide Garniture mécanique côté du moteur / côté liquide : carbure de silicium

CARATTERISTICHE TECNICHE - Technical Features - Caractéristiques Techniques
Max. temperatura liquido - Max. liquid temp. - Max. temperature du liquide : 60°C
pH Liquido pompato - pH pumped liquid - pH du liquide pompé : 6 - 10

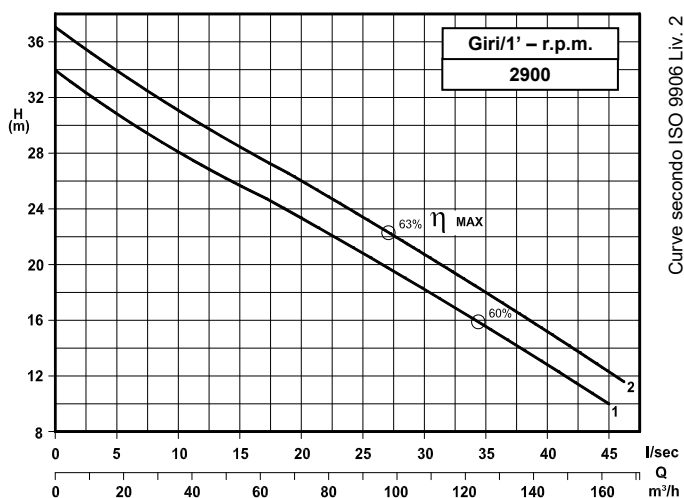

Grandezza - Size - Group 80/220

Curva Curve Courbe N°	Pompa Pump Pompe	DN	Potenza motore Motor power Puissance du moteur P2 (Kw)	Giri/1' r.p.m.
1	KB 80/2-164 A3 S2	80	11	2900
2	KB 80/2-170 A3 S2			

P2 - Potenza resa - Shaft power - Puissance sur arbre

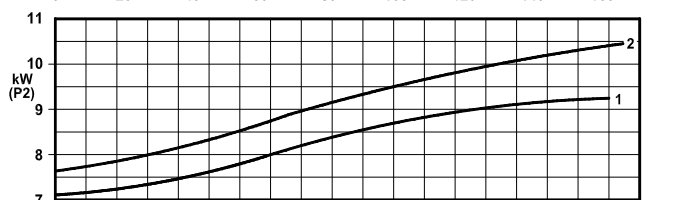

✦ Versione chopper con diffusore a taglienti e girante induriti
Chopper version with cutting diffuser and impeller hardened
Version chopper avec anneau tranchant et roue durci

DIMENSIONI DI INGOMBRO – Dimensions

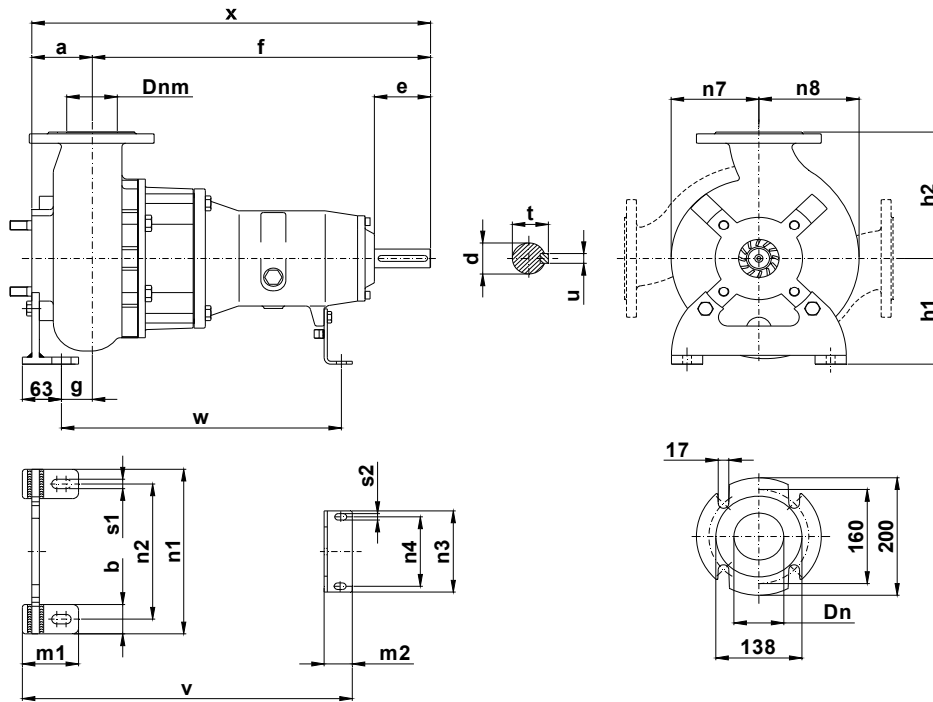

Pompa Pump Pompe	DNa DNm	a	b	c	d	e	f	g	h1	h2	m1	m2	n1	n2	n3	n4	n7	n8	s1	s2	t	u	v	w	x	Peso Weight Poids
KB 80 / .. A3S2	80	90	50	12	42	80	536	49	180	215	90	45	280	230	120	90	140	160	14	11	45	12	528	450	626	98

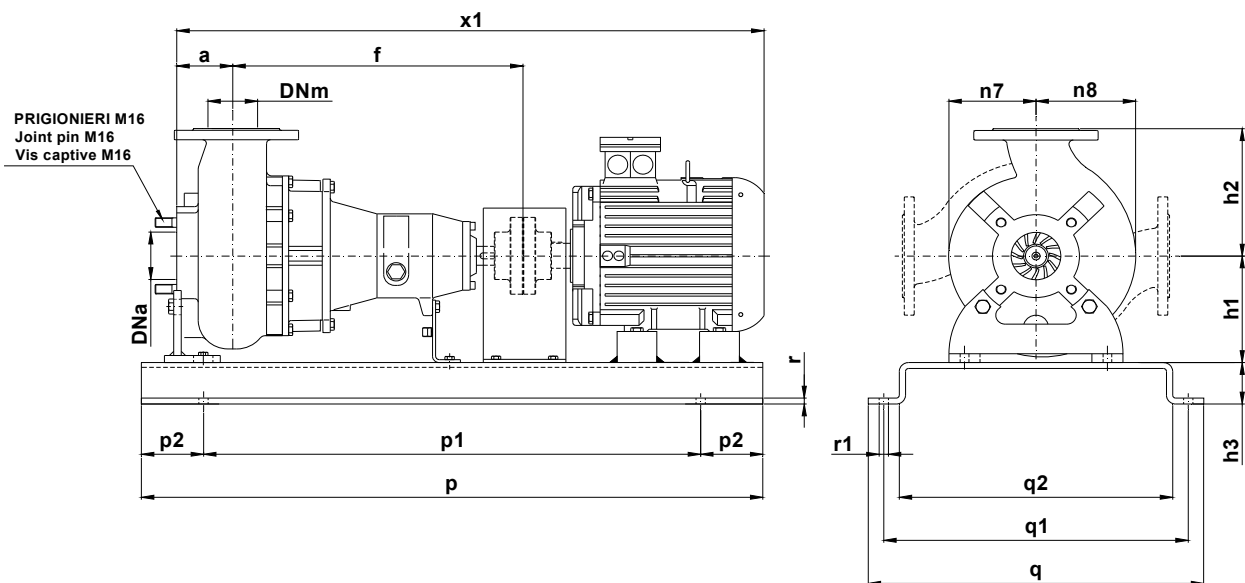

Pompa Pump Pompe	kW	Giri/1' r.p.m.	Motore Motor - Moteur MEC	h3	p	p1	p2	q	q1	q2	r	r1	x1	Peso Weight Poids
KB 80/2-150 A3 S2	7,5	2900	132	90	1200	1000	100	560	510	440	12	18	1145	264
KB 80/2-158 A3 S2														
KB 80/2-164 A3 S2	11		160*	120	1350	1150		600	564	-	-		1240	316
KB 80/2-170 A3 S2														

*Basamento in acciaio profilato saldato - Profiled welded steel base - Profilé de base en acier soudé

KB 80/2-220.1.19

Con riserva di variazioni tecniche e costruttive senza preavviso.

With reserve of technical and constructive variations without warning. Avec réserve de variations techniques et constructives sans préavis

POMPE ROTOMECC srl - 20063 CERNUSCO SUL NAVIGLIO (MI) - ITALY - Via Ponchielli, 1

Tel. +39.02.9211.0205 - +39.02.9233.0399 Fax 02.9211.0630 Sito Internet: www.pomperotomec.it E-mail: sales@pomperotomec.it



POMPE ROTOMECC

KB 80/2-220.2

DN 80

Giri/1' - r.p.m. 2900

Elettropompe centrifughe ad asse orizzontale con girante bicanale aperta e diffusore autopulente
Centrifugal horizontal pumps with channel impeller and self cleaning diffuser
Pompes à axe horizontal avec roue à canaux et anneau autonettoyant

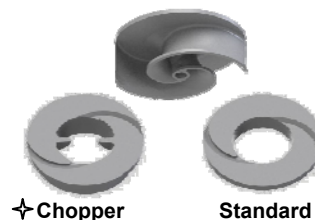
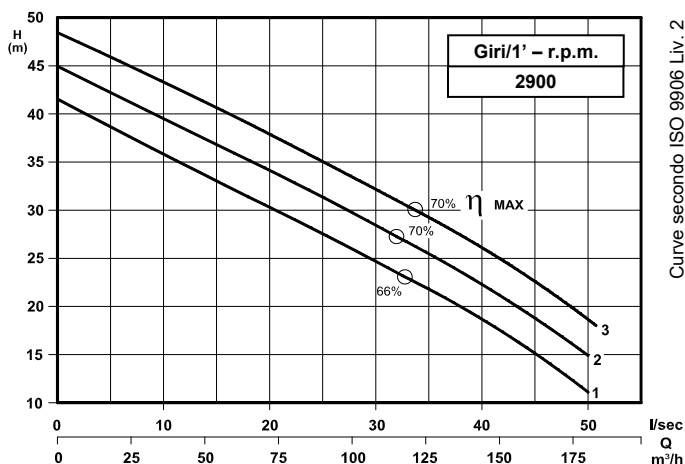

Grandezza - Size - Group 80/220

Curva Curve Courbe N°	Pompa Pump Pompe	DN	Potenza motore Motor power Puissance du moteur P2 (Kw)	Giri/1' r.p.m.
1	KB 80/2-178 A3 S2	80	15	2900
2	KB 80/2-186 A3 S2			
3	KB 80/2-193 A3 S2			

P2 - Potenza resa - Shaft power - Puissance sur arbre

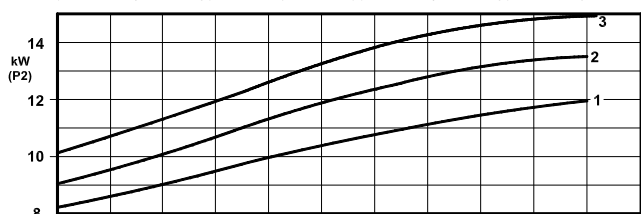

COSTRUZIONE - Materials - Matériaux

Fusioni principali - Principal parts - Parts principal	Ghisa - Cast iron - Fonte - GG 25
Girante - Impeller - Roue	Ghisa - Cast iron - Fonte - GS 500
Diffusore - Diffuser - Anneau	Ghisa - Cast iron - Fonte - GS 500
Albero - Shaft - Arbre	AISI 420
Viteria - Screws - Vis	AISI 304

TENUTE MECCANICHE - Mechanical seals - Garniture mécanique

Doppia tenuta meccanica in bagno d'olio - Double mechanical seals in oil bath - Double garniture mécanique en chambre d'huile

Tenuta lato motore / tenuta lato liquido : carburo di silicio

Motor side / liquid side mechanical seal : silicon carbide

Garniture mécanique côté du moteur / côté liquide : carbure de silicium

CARATTERISTICHE TECNICHE - Technical Features - Caractéristiques Techniques

Max. temperatura liquido - Max. liquid temp. - Max. temperature du liquide : 60°C

pH Liquido pompato - pH pumped liquid - pH du liquide pompé : 6 - 10

✦ Versione chopper con diffusore a taglienti e girante induriti
Chopper version with cutting diffuser and impeller hardened
Version chopper avec anneau tranchant et roue durci

DIMENSIONI DI INGOMBRO - Dimensions

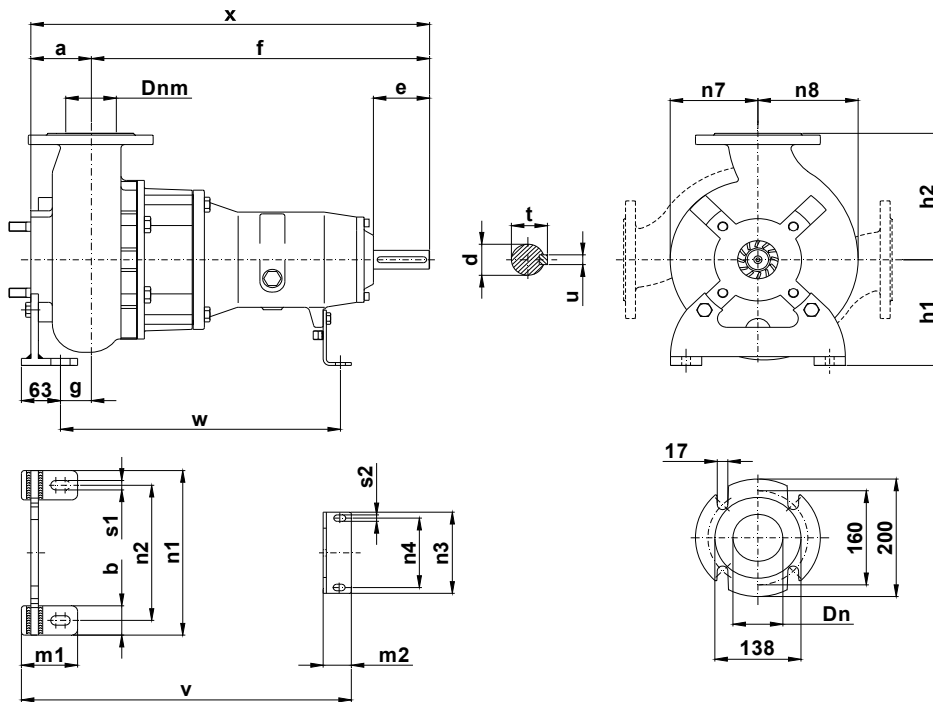

Pompa Pump Pompe	DNa DNm	a	b	c	d	e	f	g	h1	h2	m1	m2	n1	n2	n3	n4	n7	n8	s1	s2	t	u	v	w	x	Peso Weight Poids
KB 80 / .. A3S2	80	90	50	12	42	80	536	49	180	215	90	45	280	230	120	90	140	160	14	11	45	12	528	450	626	98

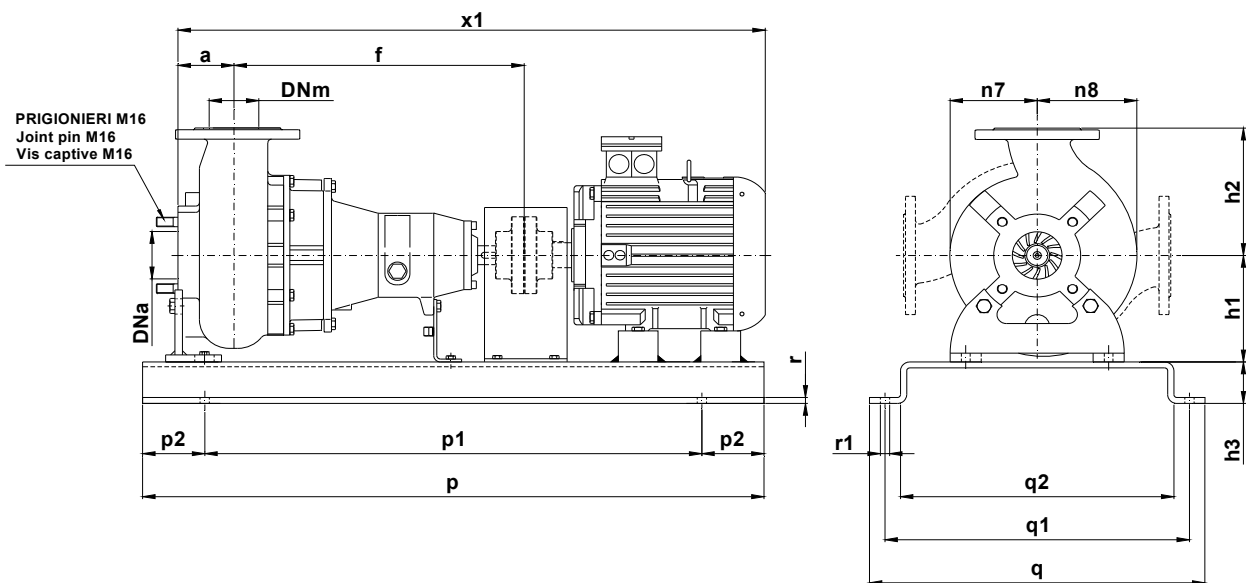

Pompa Pump Pompe	kW	Giri/1' r.p.m.	Motore Motor - Moteur MEC	h3	p	p1	p2	q	q1	q2	r	r1	x1	Peso Weight Poids
KB 80/2-178 A3 S2	15	2900	160*	120	1350	1150	100	600	564	-	-	18	1240	316
KB 80/2-186 A3 S2														
KB 80/2-193 A3 S2														

*Basamento in acciaio profilato saldato – Profiled welded steel base – Profilé de base en acier soudé

KB 80/2-220.1.19

Con riserva di variazioni tecniche e costruttive senza preavviso.

With reserve of technical and constructive variations without warning. Avec réserve de variations techniques et constructives sans préavis

POMPE ROTOMECH srl - 20063 CERNUSCO SUL NAVIGLIO (MI) - ITALY - Via Ponchielli, 1

Tel. +39.02.9211.0205 - +39.02.9233.0399 Fax 02.9211.0630 Sito Internet: www.pomperotomec.it E-mail: sales@pomperotomec.it



POMPE ROTOMECH

KB 80/2-280.1

DN 80

Giri/1' - r.p.m. 2900

Elettropompe centrifughe ad asse orizzontale con girante bicanale aperta e diffusore autopulente
Centrifugal horizontal pumps with channel impeller and self cleaning diffuser
Pompes à axe horizontal avec roue à canaux et anneau autonettoyant

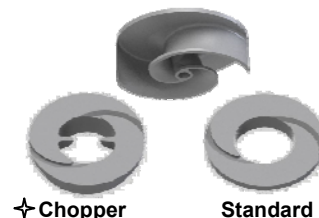
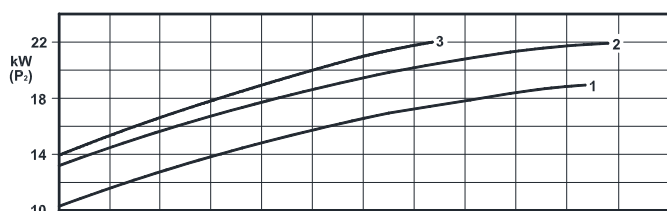
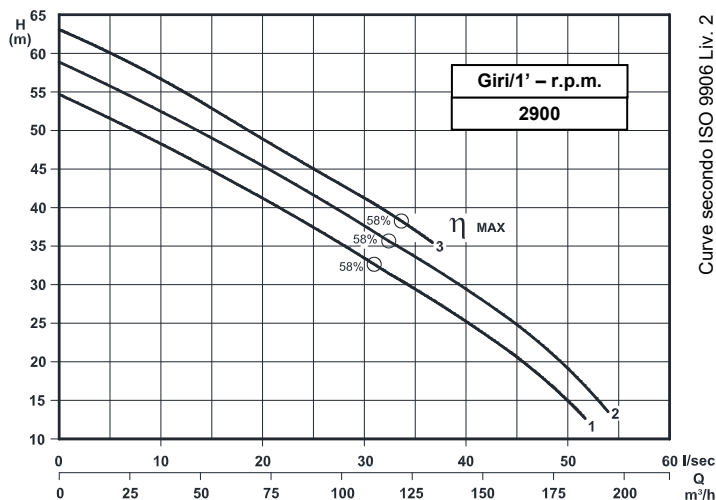

Grandezza - Size - Group 80/280

Curva Curve Courbe N°	Pompa Pump Pompe	DN	Potenza motore Motor power Puissance du moteur P2 (Kw)	Giri/1' r.p.m.
1	KB 80/2-200 A3 S2	80	22	2900
2	KB 80/2-206 A3 S2			
3	KB 80/2-212 A3 S2			

P2 - Potenza resa - Shaft power - Puissance sur arbre

COSTRUZIONE - Materials - Matériaux

Fusioni principali - Principal parts - Parts principal	Ghisa - Cast iron - Fonte - GG 25
Girante - Impeller - Roue	Ghisa - Cast iron - Fonte - GS 500
Diffusore - Diffuser - Anneau	Ghisa - Cast iron - Fonte - GS 500
Albero - Shaft - Arbre	AISI 420
Viteria - Screws - Vis	AISI 304

TENUTE MECCANICHE - Mechanical seals - Garniture mécanique

Doppia tenuta meccanica in bagno d'olio - Double mechanical seals in oil bath - Double garniture mécanique en chambre d'huile

Tenuta lato motore / tenuta lato liquido : carburo di silicio

Motor side / liquid side mechanical seal : silicon carbide

Garniture mécanique côté du moteur / côté liquide : carbure de silicium

CARATTERISTICHE TECNICHE - Technical Features - Caractéristiques Techniques

Max. temperatura liquido - Max. liquid temp. - Max. temperature du liquide : 60°C

pH Liquido pompato - pH pumped liquid - pH du liquide pompé: 6 - 10

✦ Versione chopper con diffusore a taglienti e girante induriti
Chopper version with cutting diffuser and impeller hardened
Version chopper avec anneau tranchant et roue durci

DIMENSIONI DI INGOMBRO – Dimensions

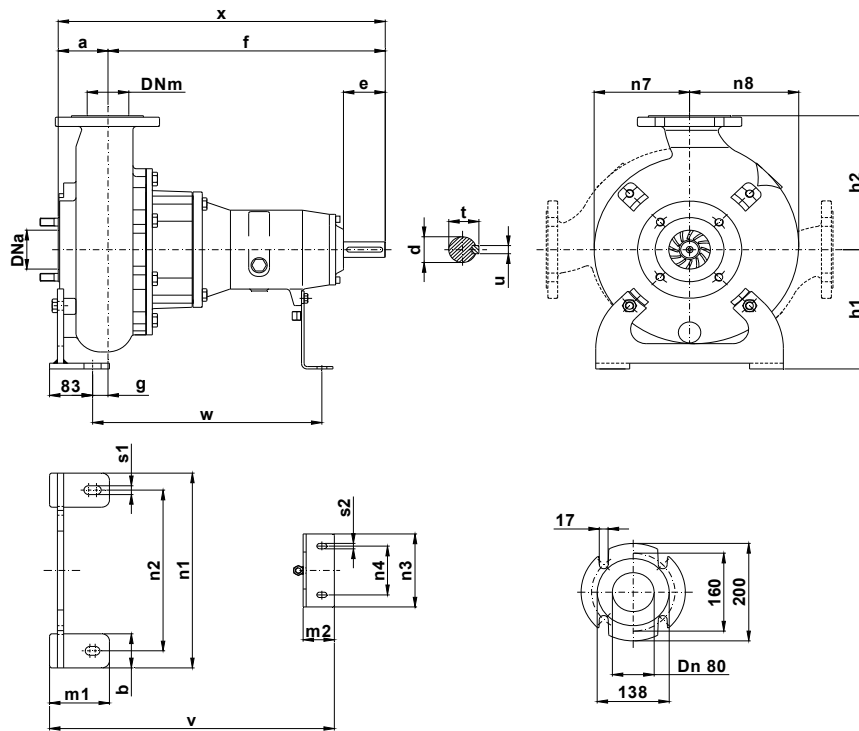

Pompa Pump Pompe	DNa DNm	a	b	c	d	e	f	g	h1	h2	m1	m2	n1	n2	n3	n4	n7	n8	s1	s2	t	u	v	w	x	Peso Weight Poids
KB 80 / .. A3S2	80	95	70	12	42	80	536	49	245	275	115	45	330	400	160	110	185	210	18	11	45	12	546	440	631	118

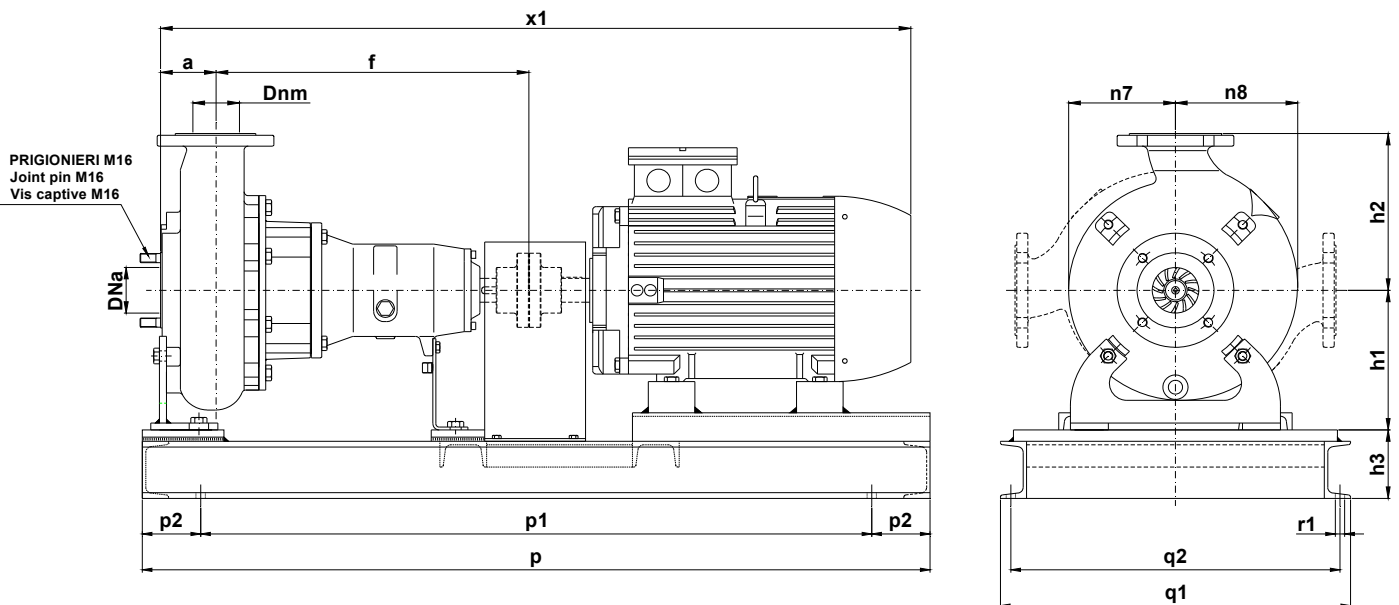

Pompa Pump Pompe	kW	Giri/1' r.p.m.	Motore Motor - Moteur MEC	h3	p	p1	p2	q	q1	q2	r	r1	x1	Peso Weight Poids
KB 80/2-200 A3 S2	22	2900	180	120	1350	1150	100	600	564	-	-	18	1316	322
KB 80/2-206 A3 S2														
KB 80/2-212 A3 S2														

KB 80/2-220.1.19

Con riserva di variazioni tecniche e costruttive senza preavviso.

With reserve of technical and constructive variations without warning. Avec réserve de variations techniques et constructives sans préavis

POMPE ROTOMECC s.r.l. - 20063 CERNUSCO SUL NAVIGLIO (MI) - ITALY - Via Ponchielli, 1

Tel. +39.02.9211.0205 - +39.02.9233.0399 Fax 02 9211.0630 Sito Internet: www.pomperotomec.it E-mail: sales@pomperotomec.it