



POMPE ROTOMECC

Elettropompe centrifughe ad asse orizzontale con girante arretrata a vortice
Centrifugal horizontal pumps with vortex impeller
Pompes à axe horizontal avec roue vortex

KS 200/6-375.1

DN 200

Giri/1' - r.p.m.
960

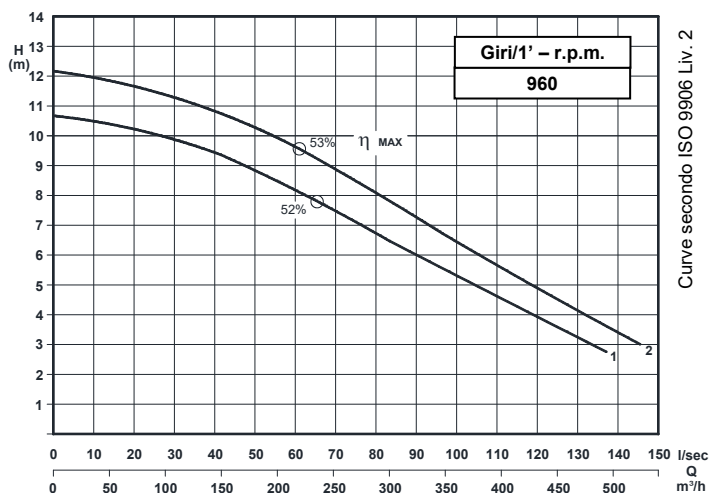

Grandezza - Size - Group 200/375

Curva Curve Courbe N°	Pompa Pump Pompe	DN	Potenza motore Motor power Puissance du moteur P2 (Kw)	Giri/1' r.p.m.	Passaggio libero Free passage Section de passage
1	KS 200/6-310K11 A4 S3	200	15	960	110
2	KS 200/6-330K11 A4 S3				

P2 - Potenza resa - Shaft power - Puissance sur arbre



COSTRUZIONE - Materials - Matériaux	
Fusioni principali - Principal parts - Parts principal	Ghisa - Cast iron - Fonte - GG 25
Girante - Impeller - Roue	Ghisa - Cast iron - Fonte - GS 500
Albero - Shaft - Arbre	AISI 420
Viteria - Screws - Vis	AISI 304

TENUTE MECCANICHE - Mechanical seals - Garniture mécanique
Doppia tenuta meccanica in bagno d'olio - Double mechanical seals in oil bath - Double garniture mécanique en chambre d'huile
Tenuta lato motore / tenuta lato liquido : carburo di silicio
Motor side / liquid side mechanical seal : silicon carbide
Garniture mécanique côté du moteur / côté liquide : carbure de silicium

CARATTERISTICHE TECNICHE - Technical Features - Caractéristiques Techniques
Max. temperatura liquido - Max. liquid temp. - Max. temperature du liquide : 60°C
pH Liquido pompato - pH pumped liquid - pH du liquide pompé: 6 - 10

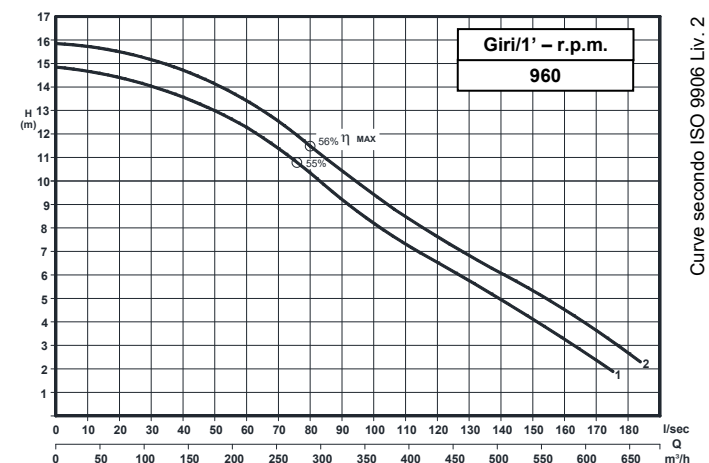

Grandezza - Size - Group 200/375

Curva Curve Courbe N°	Pompa Pump Pompe	DN	Potenza motore Motor power Puissance du moteur P2 (Kw)	Giri/1' r.p.m.	Passaggio libero Free passage Section de passage
1	KS 200/6-365K11 A4 S3	200	22	960	110
2	KS 200/6-374K11 A4 S3				

P2 - Potenza resa - Shaft power - Puissance sur arbre

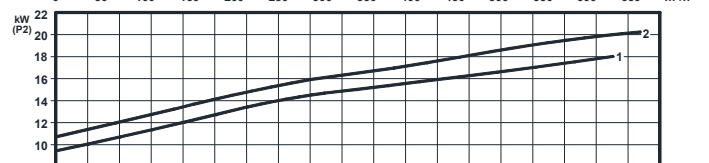

DIMENSIONI DI INGOMBRO – Dimensions

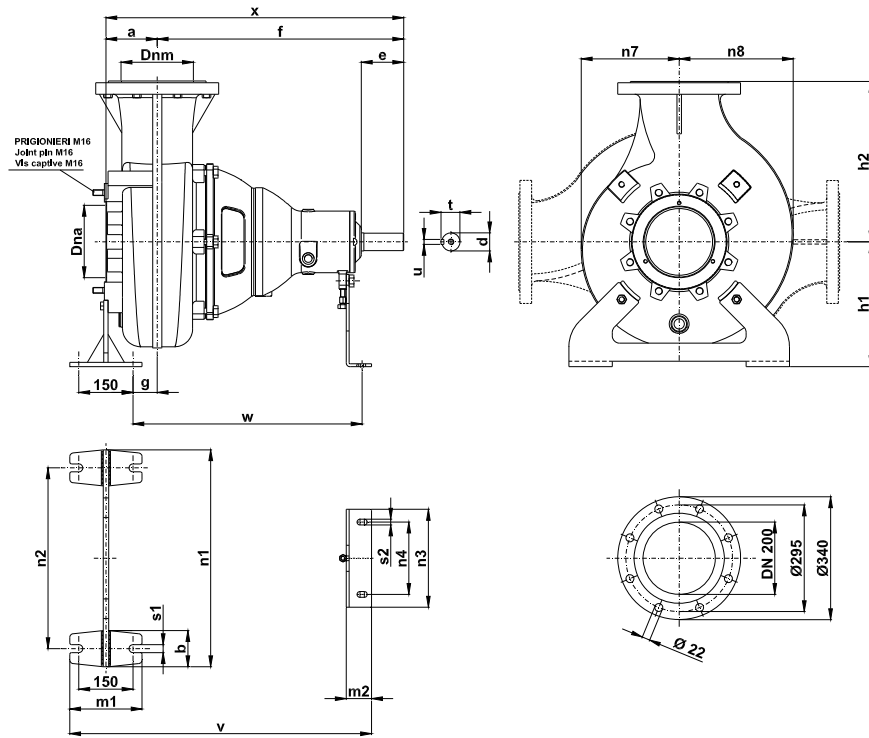

Pompa Pump Pompe	DNa DNm	a	b	c	d	e	f	g	h1	h2	m1	m2	n1	n2	n3	n4	n7	n8	s1	s2	t	u	v	w	x	Peso Weight Poids
KS 200 / .. A4S3	200	142	100	15	48	110	685	56	345	400	200	70	600	200	270	285	259	295	22	20	52	12	835	634	827	250

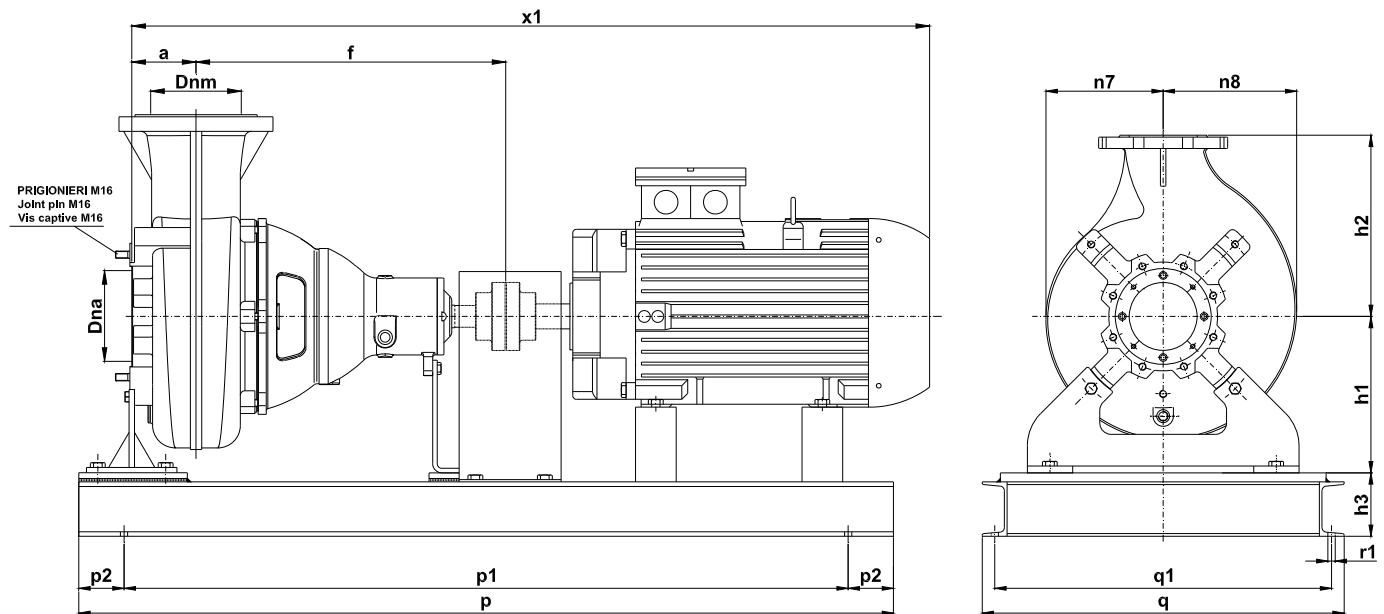

Pompa Pump Pompe	kW	Giri/1' r.p.m.	Motore Motor - Moteur MEC	h3	p	p1	p2	q	q1	r1	x1
KS 200/6-310K11 A4 S3	15	960	180	140	1800	1600	100	800	744	16	1547
KS 200/6-330K11 A4 S3											
KS 200/6-365K11 A4 S3	22	960	180	140	1800	1600	100	800	744	16	1597
KS 200/6-374K11 A4 S3											

KS 200/6-375.1.19

Con riserva di variazioni tecniche e costruttive senza preavviso.

With reserve of technical and constructive variations without warning. Avec réserve de variations techniques et constructives sans préavis

POMPE ROTOMECH srl - 20063 CERNUSCO SUL NAVIGLIO (MI) - ITALY - Via Ponchielli, 1

Tel. +39.02.9211.0205 - +39.02.9233.0399 Fax 02.9211.0630 Sito Internet: www.pomperotomech.it E-mail: sales@pomperotomech.it