



POMPE ROTOMECC

Elettropompe centrifughe ad asse orizzontale con girante arretrata a vortice
Centrifugal horizontal pumps with vortex impeller
Pompes à axe horizontal avec roue vortex

KS 50/6-220.1

DN 50

Giri/1' - r.p.m

960

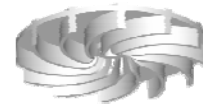
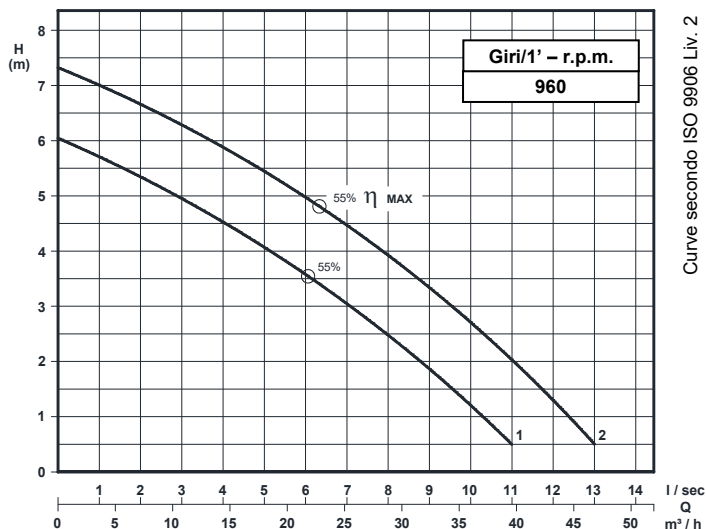

Grandezza - Size - Group 50/220

Curva Curve Courbe N°	Pompa Pump Pompe	DN	Potenza motore Motor power Puissance du moteur P2 (Kw)	Giri/1' r.p.m.	Passaggio libero Free passage Section de passage
1	KS 50/6-200B A1 S1	50	1,5	960	50
2	KS 50/6-219B A1 S1				

P2 - Potenza resa - Shaft power - Puissance sur arbre

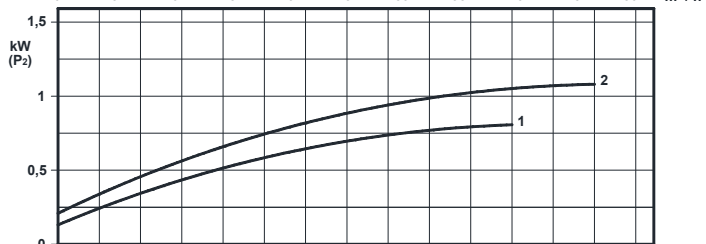

COSTRUZIONE - Materials - Matériaux

Fusioni principali - Principal parts - Parts principal	Ghisa - Cast iron - Fonte - GG 25
Girante - Impeller - Roue	Ghisa - Cast iron - Fonte - GG 25
Albero - Shaft - Arbre	AISI 420
Viteria - Screws - Vis	AISI 304

TENUTE MECCANICHE - Mechanical seals - Garniture mécanique

Doppia tenuta meccanica in bagno d'olio - Double mechanical seals in oil bath - Double garniture mécanique en chambre d'huile
 Tenuta lato motore / tenuta lato liquido : carburo di silicio
 Motor side / liquid side mechanical seal : silicon carbide
 Garniture mécanique côté du moteur / côté liquide : carbure de silicium

CARATTERISTICHE TECNICHE - Technical Features - Caractéristiques Techniques

Max. temperatura liquido - Max. liquid temp. - Max. temperature du liquide : 60°C
pH Liquido pompato - pH pumped liquid - pH du liquide pompé : 6 - 10

DIMENSIONI DI INGOMBRO - Dimensions

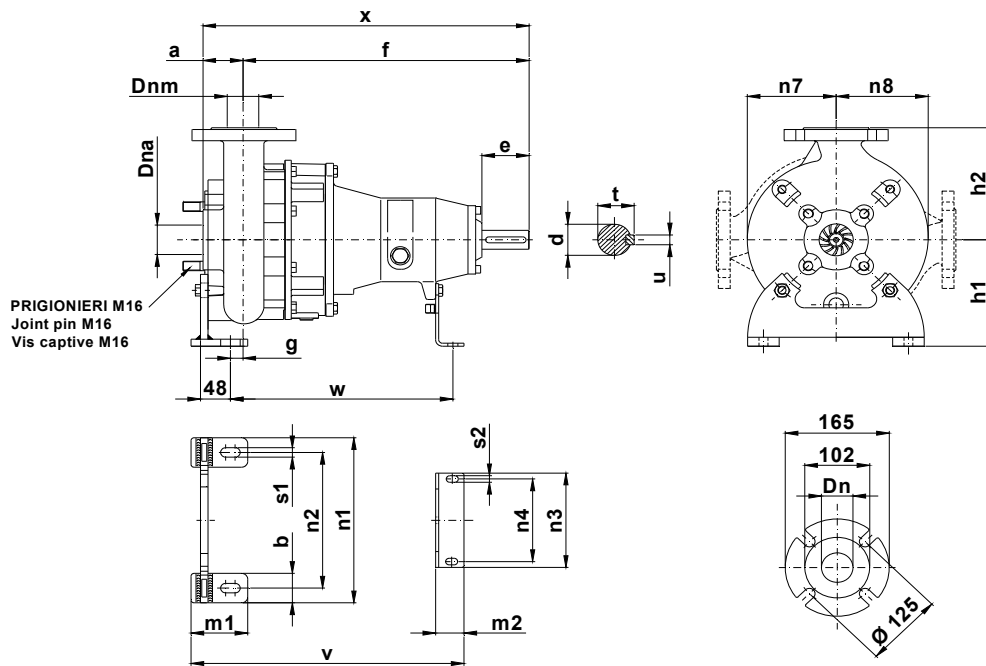

Pompa Pump Pompe	DNa DNm	a	b	c	d	e	f	g	h1	h2	m1	m2	n1	n2	n3	n4	n7	n8	s1	s2	t	u	v	w	x	Peso Weight Poids
KS 50 / .. A1S1	50	65	50	12	32	78	458	22	180	215	90	45	280	230	120	90	140	160	16	11	35	10	433	355	523	62

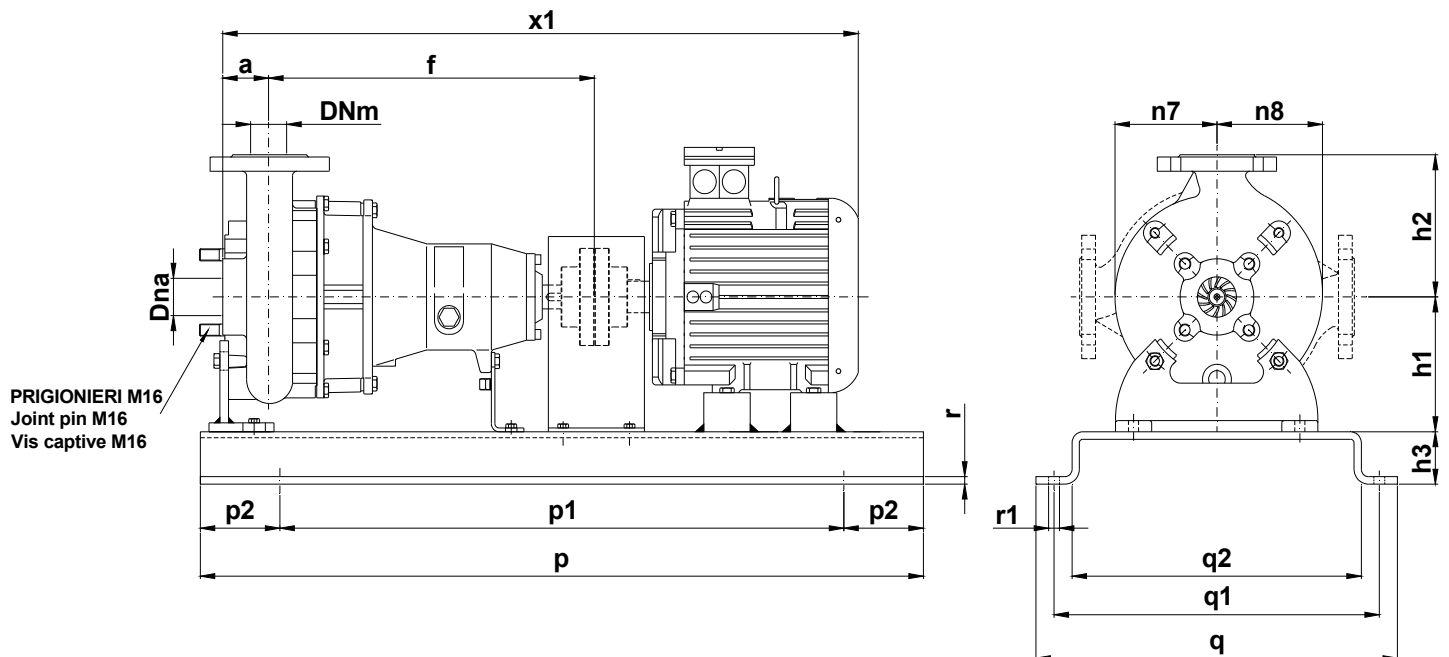

Pompa Pump Pompe	kW	Giri/1' r.p.m.	Motore Motor - Moteur MEC	h3	p	p1	p2	q	q1	q2	r	r1	x1	Peso Weight Poids
KS 50/6-200B A1 S1	1,5	960	100	70	1000	800	100	540	490	440	10	16	910	130
KS 50/6-200B A1 S1														

KS 50/6-220.1.19

Con riserva di variazioni tecniche e costruttive senza preavviso.

With reserve of technical and constructive variations without warning. Avec réserve de variations techniques et constructives sans préavis

POMPE ROTOMECC s.r.l. - 20063 CERNUSCO SUL NAVIGLIO (MI) - ITALY - Via Ponchielli, 1

Tel. +39.02.9211.0205 - +39.02.9233.0399 Fax 02.9211.0630 Sito Internet: www.pomperotomec.it E-mail: sales@pomperotomec.it



POMPE ROTOMECC

Elettropompe centrifughe ad asse orizzontale con girante arretrata a vortice
Centrifugal horizontal pumps with vortex impeller
Pompes à axe horizontal avec roue vortex

KS 50/4-220.1

DN 50

Giri/1' - r.p.m

1450

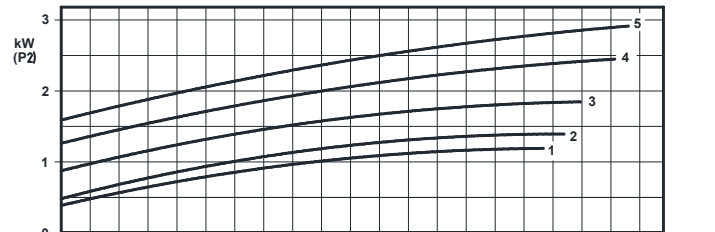
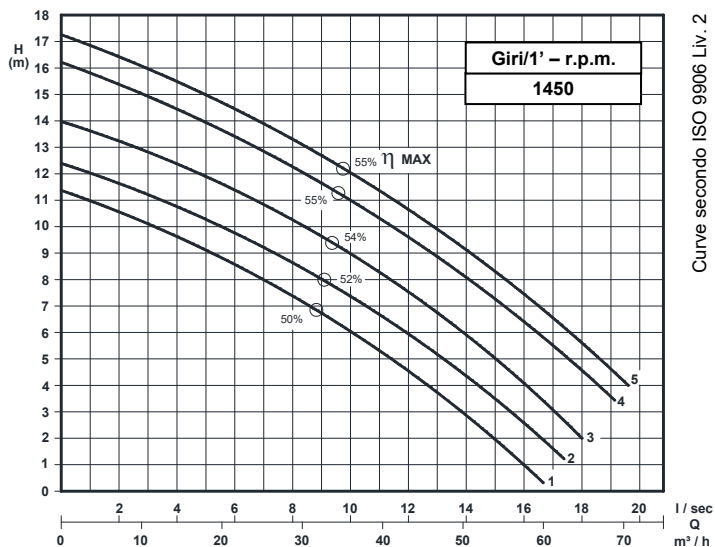
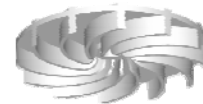

Grandezza - Size - Group 50/220

Curva Curve Courbe N°	Pompa Pump Pompe	DN	Potenza motore Motor power Puissance du moteur P ₂ (Kw)	Giri/1' r.p.m.	Passaggio libero Free passage Section de passage
1	KS 50-180B A1 S1	50	1,5	1450	50
2	KS 50-190B A1 S1				
3	KS 50-200B A1 S1		2,2		45
4	KS 50-219B A1 S1				
5	KS 50-219C A1 S1				

P₂ - Potenza resa - Shaft power - Puissance sur arbre

COSTRUZIONE - Materials - Matériaux	
Fusioni principali - Principal parts - Parts principal	Ghisa - Cast iron - Fonte - GG 25
Girante - Impeller - Roue	Ghisa - Cast iron - Fonte - GG 25
Albero - Shaft - Arbre	AISI 420
Viteria - Screws - Vis	AISI 304

TENUTE MECCANICHE - Mechanical seals - Garniture mécanique
Doppia tenuta meccanica in bagno d'olio - Double mechanical seals in oil bath - Double garniture mécanique en chambre d'huile
Tenuta lato motore / tenuta lato liquido : carburo di silicio
Motor side / liquid side mechanical seal : silicon carbide
Garniture mécanique côté du moteur / côté liquide : carbure de silicium

CARATTERISTICHE TECNICHE - Technical Features - Caractéristiques Techniques
Max. temperatura liquido - Max. liquid temp. - Max. temperature du liquide : 60°C
pH Liquido pompato - pH pumped liquid - pH du liquide pompé : 6 - 10



POMPE ROTOMECC

Elettropompe centrifughe ad asse orizzontale con girante arretrata a vortice
Centrifugal horizontal pumps with vortex impeller
Pompes à axe horizontal avec roue vortex

KS 50/2-220.1

DN 50

Giri/1' - r.p.m

2900

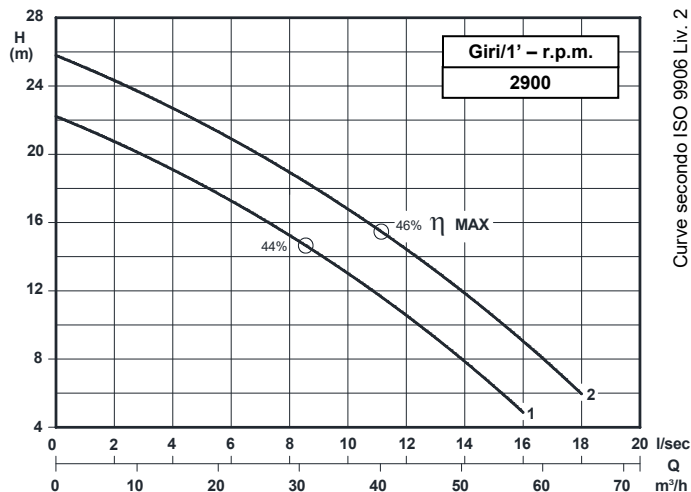

Grandezza - Size - Group 50/220

Curva Curve Courbe N°	Pompa Pump Pompe	DN	Potenza motore Motor power Puissance du moteur P ₂ (Kw)	Giri/1' r.p.m.	Passaggio libero Free passage Section de passage
1	KS 50/2-140K1 A1 S1	50	3	2900	40
2	KS 50/2-155K1 A1 S1		4		

P₂ - Potenza resa - Shaft power - Puissance sur arbre

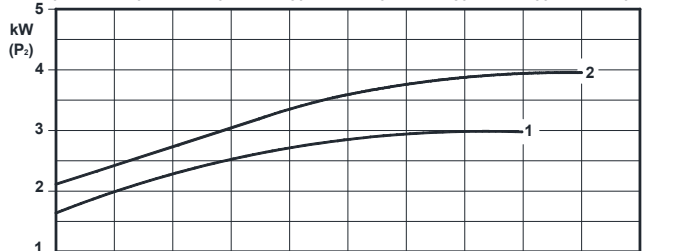

COSTRUZIONE - Materials - Matériaux	
Fusioni principali - Principal parts - Parts principal	Ghisa - Cast iron - Fonte - GG 25
Girante - Impeller - Roue	Ghisa - Cast iron - Fonte - GG 25
Albero - Shaft - Arbre	AISI 420
Viteria - Screws - Vis	AISI 304

TENUTE MECCANICHE - Mechanical seals - Garniture mécanique
Doppia tenuta meccanica in bagno d'olio - Double mechanical seals in oil bath - Double garniture mécanique en chambre d'huile
Tenuta lato motore / tenuta lato liquido : carburo di silicio Motor side / liquid side mechanical seal : silicon carbide Garniture mécanique côté du moteur / côté liquide : carbure de silicium

CARATTERISTICHE TECNICHE - Technical Features - Caractéristiques Techniques
Max. temperatura liquido - Max. liquid temp. - Max. temperature du liquide : 60°C
pH Liquido pompato - pH pumped liquid - pH du liquide pompé : 6 - 10

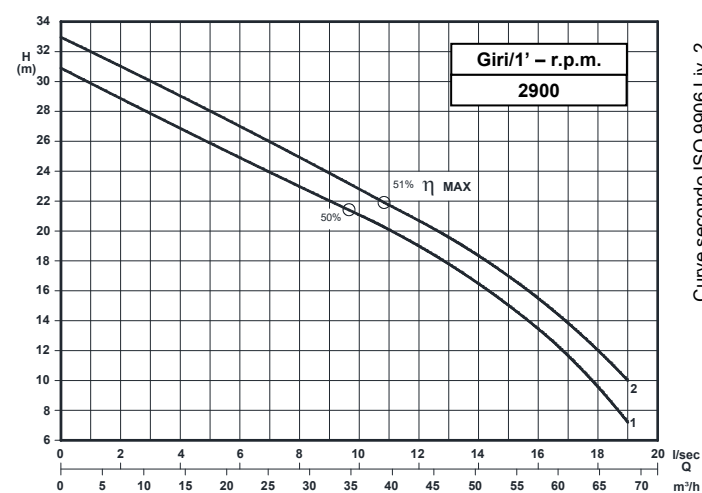

Grandezza - Size - Group 50/220

Curva Curve Courbe N°	Pompa Pump Pompe	DN	Potenza motore Motor power Puissance du moteur P ₂ (Kw)	Giri/1' r.p.m.	Passaggio libero Free passage Section de passage
1	KS 50/2-163K2 A1 S1	50	5,5	2900	40
2	KS 50/2-168K2 A1 S1				

P₂ - Potenza resa - Shaft power - Puissance sur arbre

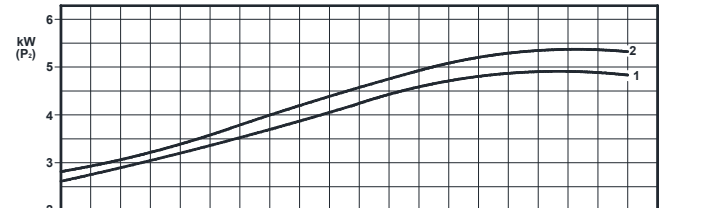

DIMENSIONI DI INGOMBRO – Dimensions

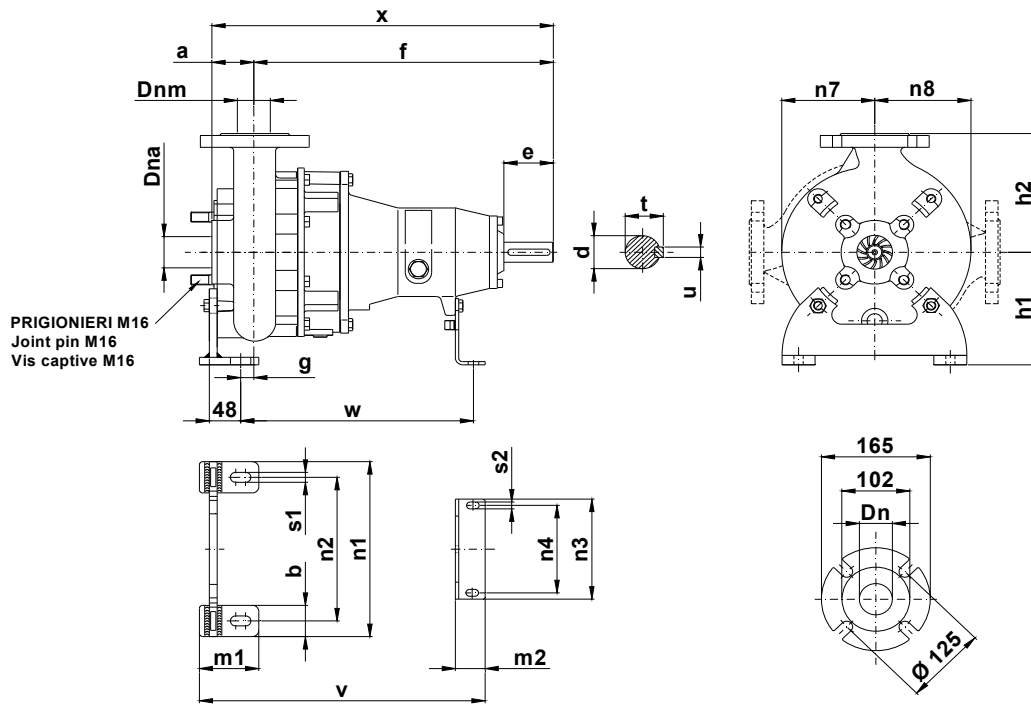

Pompa Pump Pompe	DNa DNm	a	b	c	d	e	f	g	h1	h2	m1	m2	n1	n2	n3	n4	n7	n8	s1	s2	t	u	v	w	x	Peso Weight Poids
KS 50 / .. A1 S1	50	65	50	12	32	78	458	22	180	215	90	45	280	230	120	90	140	160	16	11	35	10	433	355	523	62

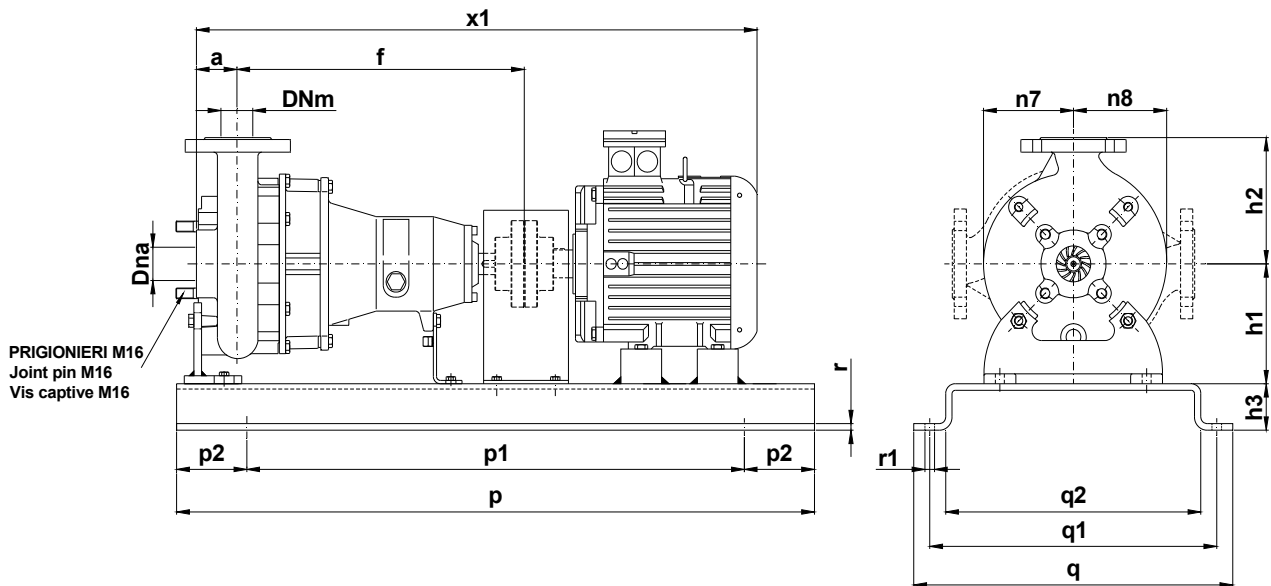

Pompa Pump Pompe	kW	Giri/1' r.p.m.	Motore Motor - Moteur MEC	h3	p	p1	p2	q	q1	q2	r	r1	x1	Peso Weight Poids
KS 50/2-140K1 A1 S1	3	2900	100	70	1000	800	100	540	490	440	10	16	910	125
KS 50/2-155K1 A1 S1	4		112										930	135
KS 50/2-163K2 A1 S1	5,5		132	90	1200	1000	560	510	12	18	1040	139		
KS 50/2-168K2 A1 S1														

KS 50/2-220.1.19

Con riserva di variazioni tecniche e costruttive senza preavviso.

With reserve of technical and constructive variations without warning. Avec réserve de variations techniques et constructives sans préavis

POMPE ROTOMECH srl - 20063 CERNUSCO SUL NAVIGLIO (MI) - ITALY - Via Ponchielli, 1

Tel. +39.02.9211.0205 - +39.02.9233.0399 Fax 02.9211.0630 Sito Internet: www.pomperotomec.it E-mail: sales@pomperotomec.it



POMPE ROTOMECC

Elettropompe centrifughe ad asse orizzontale con girante arretrata a vortice
Centrifugal horizontal pumps with vortex impeller
Pompes à axe horizontal avec roue vortex

KS 50/2-220.2

DN 50

Giri/1' - r.p.m.
2900

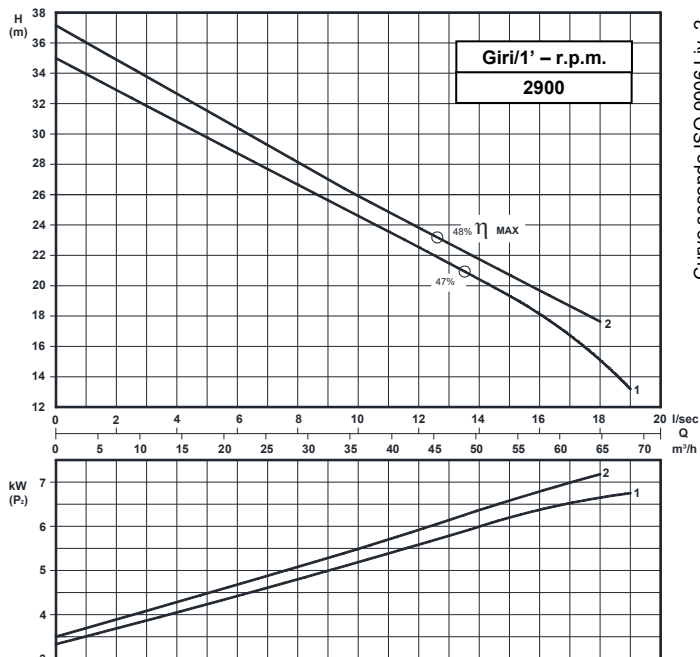

Curve secondo ISO 9906 Liv. 2



Grandezza - Size - Group 50/220

Curva Curve Courbe N°	Pompa Pump Pompe	DN	Potenza motore Motor power Puissance du moteur P2 (Kw)	Giri/1' r.p.m.	Passaggio libero Free passage Section de passage
1	KS 50/2-175K3 A3 S2	50	7,5	2900	40
2	KS 50/2-180K3 A3 S2				

P2 - Potenza resa - Shaft power - Puissance sur arbre

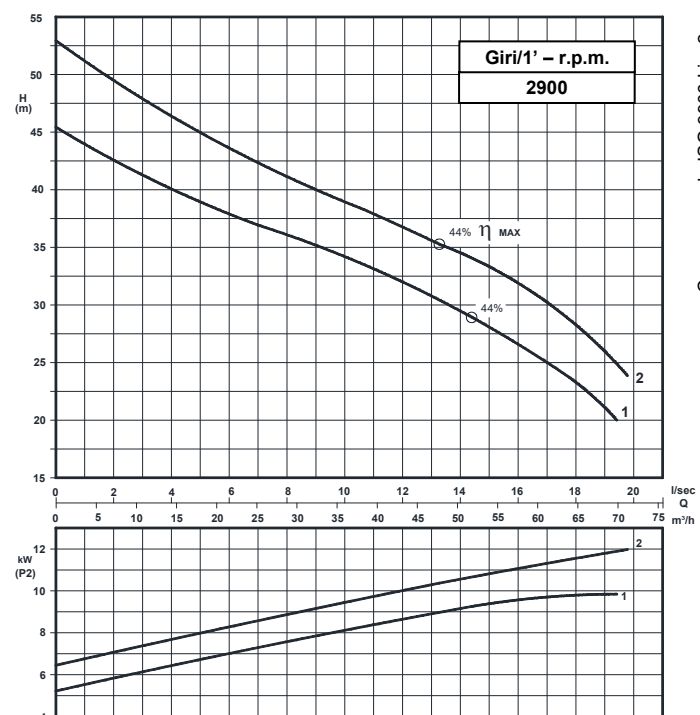

Curve secondo ISO 9906 Liv. 2

COSTRUZIONE - Materials - Matériaux	
Fusioni principali - Principal parts - Parts principal	Ghisa - Cast iron - Fonte - GG 25
Girante - Impeller - Roue	Ghisa - Cast iron - Fonte - GG 25
Albero - Shaft - Arbre	AISI 420
Viteria - Screws - Vis	AISI 304

TENUTE MECCANICHE - Mechanical seals - Garniture mécanique
Doppia tenuta meccanica in bagno d'olio - Double mechanical seals in oil bath - Double garniture mécanique en chambre d'huile
Tenuta lato motore / tenuta lato liquido : carburo di silicio
Motor side / liquid side mechanical seal : silicon carbide
Garniture mécanique côté du moteur / côté liquide : carbure de silicium

CARATTERISTICHE TECNICHE - Technical Features - Caractéristiques Techniques
Max. temperatura liquido - Max. liquid temp. - Max. temperature du liquide : 60°C
pH Liquido pompato - pH pumped liquid - pH du liquide pompé : 6 - 10

Grandezza - Size - Group 50/220

Curva Curve Courbe N°	Pompa Pump Pompe	DN	Potenza motore Motor power Puissance du moteur P2 (Kw)	Giri/1' r.p.m.	Passaggio libero Free passage Section de passage
1	KS 50/2-201 A3 S2	50	11	2900	35
2	KS 50/2-219 A3 S2		15		

P2 - Potenza resa - Shaft power - Puissance sur arbre

DIMENSIONI DI INGOMBRO – Dimensions

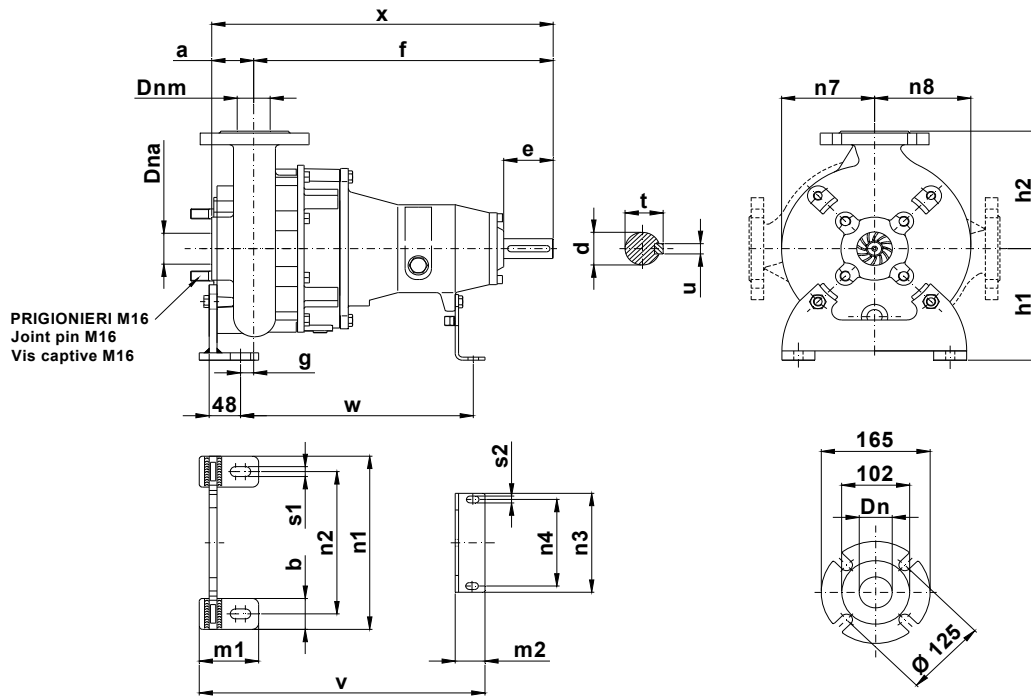

Pompa Pump Pompe	DNa DNm	a	b	c	d	e	f	g	h1	h2	m1	m2	n1	n2	n3	n4	n7	n8	s1	s2	t	u	v	w	x	Peso Weight Poids
KS 50 / .. A3S2	50	65	50	12	42	80	526	22	180	215	90	45	280	230	120	90	140	160	14	11	45	12	477	410	591	82

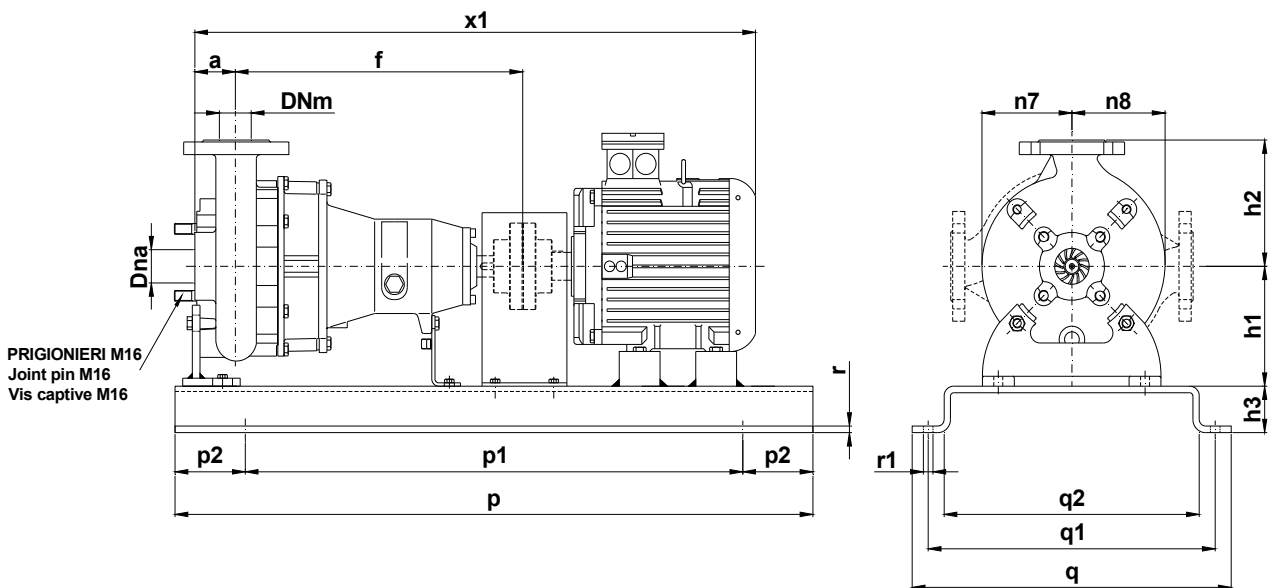

Pompa Pump Pompe	kW	Giri/1' r.p.m.	Motore Motor - Moteur MEC	h3	p	p1	p2	q	q1	q2	r	r1	x1	Peso Weight Poids
KS 50/2-175K3 A3 S2	7,5	2900	132	90	1200	1000	100	560	510	440	12	18	1110	250
KS 50/2-180K3 A3 S2													300	
KS 50/2-201 A3 S2	11		160	100	1350	1150	100	600	564	440	12	18	1205	310
KS 50/2-219 A3 S2	15												310	

KS 50/2-220.1.19

Con riserva di variazioni tecniche e costruttive senza preavviso.

With reserve of technical and constructive variations without warning. Avec réserve de variations techniques et constructives sans préavis

POMPE ROTOMECC s.r.l. - 20063 CERNUSCO SUL NAVIGLIO (MI) - ITALY - Via Ponchielli, 1

Tel. +39.02.9211.0205 - +39.02.9233.0399 Fax 02 9211.0630 Sito Internet: www.pomperotomec.it E-mail: sales@pomperotomec.it