



POMPE ROTOMECC

Elettropompe centrifughe ad asse orizzontale con girante arretrata a vortice
Centrifugal horizontal pumps with vortex impeller
Pompes à axe horizontal avec roue vortex

KS 65/6-220.1

DN 65

Giri/1' - r.p.m.
960

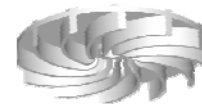
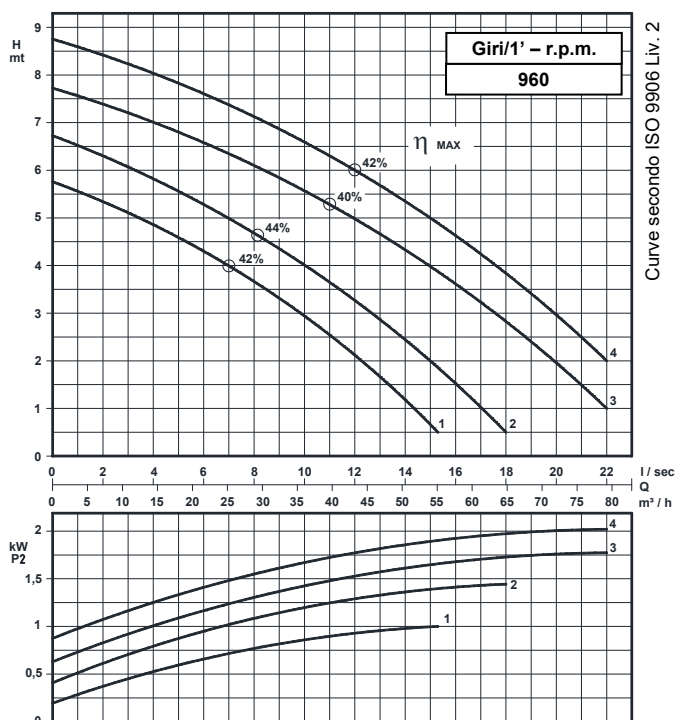

Grandezza - Size - Group 65/220

Curva Curve Courbe N°	Pompa Pump Pompe	DN	Potenza motore Motor power Puissance du moteur P2 (Kw)	Giri/1' r.p.m.	Passaggio libero Free passage Section de passage
1	KS 65/6-200B A1 S1	65	1,5	960	60
2	KS 65/6-219B A1 S1				
3	KS 65/6-210F A2 S1		2,2		45
4	KS 65/6-219F A2 S1				

P2 - Potenza resa - Shaft power - Puissance sur arbre

COSTRUZIONE - Materials - Matériaux

Fusioni principali - Principal parts - Parts principal	Ghisa - Cast iron - Fonte - GG 25
Girante - Impeller - Roue	Ghisa - Cast iron - Fonte - GG 25
Albero - Shaft - Arbre	AISI 420
Viteria - Screws - Vis	AISI 304

TENUTE MECCANICHE - Mechanical seals - Garniture mécanique

Doppia tenuta meccanica in bagno d'olio - Double mechanical seals in oil bath - Double garniture mécanique en chambre d'huile
Tenuta lato motore / tenuta lato liquido : carburo di silicio Motor side / liquid side mechanical seal : silicon carbide Garniture mécanique côté du moteur / côté liquide : carbure de silicium

CARATTERISTICHE TECNICHE - Technical Features - Caractéristiques Techniques

Max. temperatura liquido - Max. liquid temp. - Max. temperature du liquide : 60°C
pH Liquido pompato - pH pumped liquid - pH du liquide pompé : 6 - 10

DIMENSIONI DI INGOMBRO – Dimensions

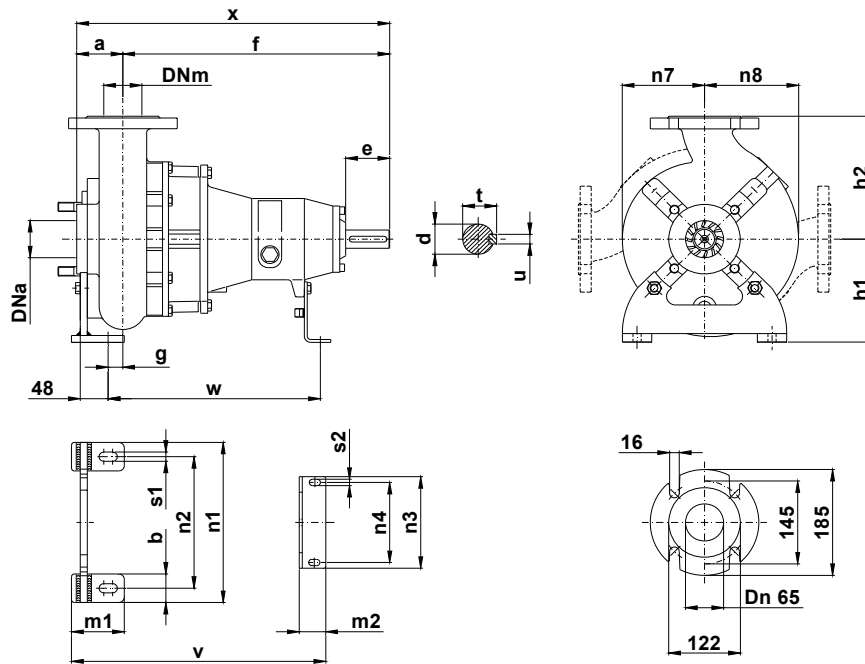

Pompa Pump Pompe	DNa DNm	a	b	c	d	e	f	g	h1	h2	m1	m2	n1	n2	n3	n4	n7	n8	s1	s2	t	u	v	w	x	Peso Weight Poids
KS 65 / .. A1S1 KS 65 / .. A2S1	65	70	50	12	32	80	460	26	180	215	75	45	280	230	120	90	140	160	16	11	35	10	424	360	530	64

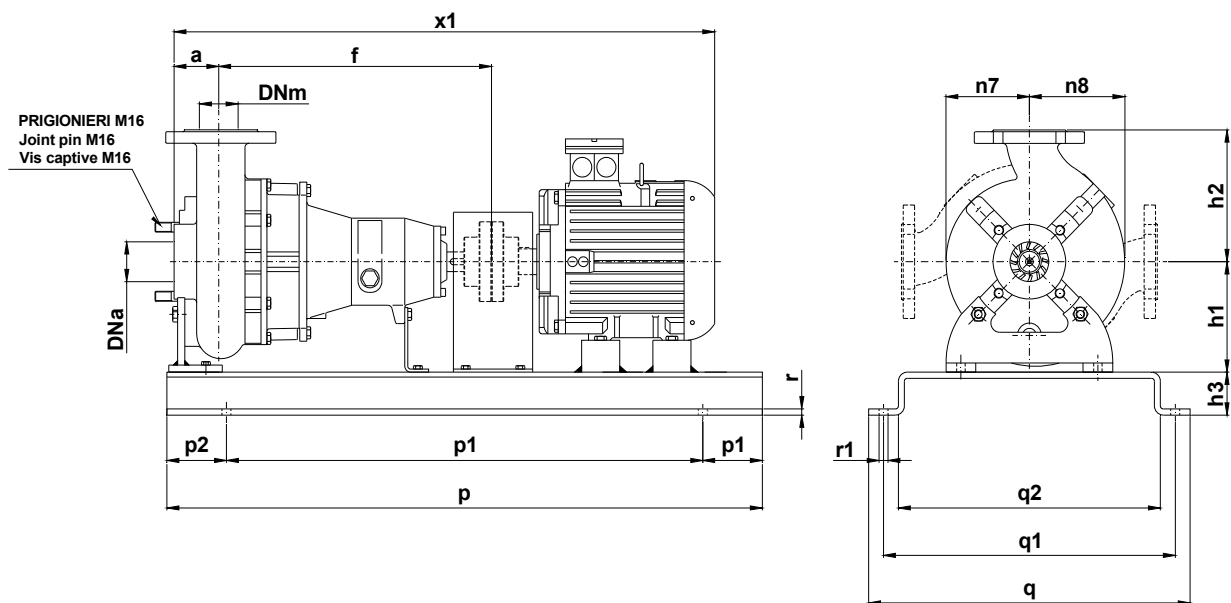

Pompa Pump Pompe	kW	Giri/1' r.p.m.	Motore Motor - Moteur MEC	h3	p	p1	p2	q	q1	q2	r	r1	x1	Peso Weight Poids
KS 65/6-200B A1 S1	1,5	960	100	70	1000	800	100	540	490	440	10	16	920	132
KS 65/6-219B A1 S1													940	142
KS 65/6-210F A2 S1	2,2	960	112	70	1000	800	100	540	490	440	10	16	920	132
KS 65/6-219F A2 S1													940	142

KS 65/6-220.1.19

Con riserva di variazioni tecniche e costruttive senza preavviso.

With reserve of technical and constructive variations without warning. Avec réserve de variations techniques et constructives sans préavis

POMPE ROTOMECC srl - 20063 CERNUSCO SUL NAVIGLIO (MI) - ITALY - Via Ponchielli, 1

Tel. +39.02.9211.0205 - +39.02.9233.0399 Fax 02.9211.0630 Sito Internet: www.pomperotomec.it E-mail: sales@pomperotomec.it



POMPE ROTOMECC

Elettropompe centrifughe ad asse orizzontale con girante arretrata a vortice
Centrifugal horizontal pumps with vortex impeller
Pompes à axe horizontal avec roue vortex

KS 65/4-220.1

DN 65

Giri/1' - r.p.m.
1450

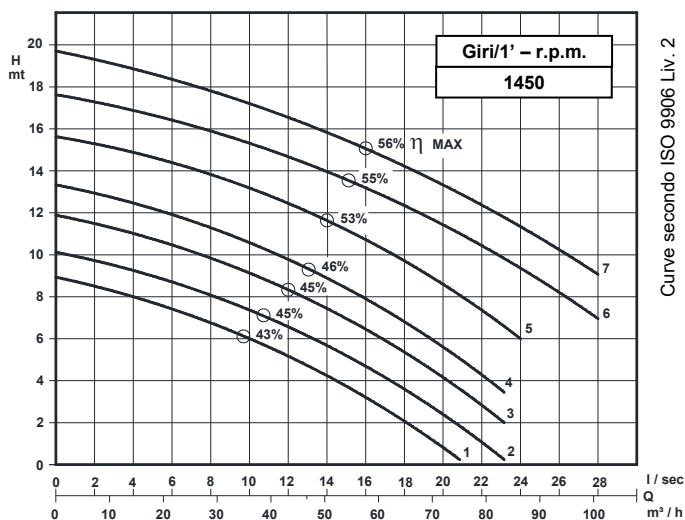

Grandezza - Size - Group 65/220

Curva Curve Courbe N°	Pompa Pump Pompe	DN	Potenza motore Motor power Puissance du moteur P2 (Kw)	Giri/1' r.p.m.	Passaggio libero Free passage Section de passage
1	KS 65-170B A1 S1	65	1,5	1450	60
2	KS 65-180B A1 S1		2,2		
3	KS 65-200B A1 S1		3		
4	KS 65-219B A1 S1		4		55
5	KS 65-219C A1 S1		5,5		45
6	KS 65-210F A2 S1				
7	KS 65-219F A2 S1				

P2 - Potenza resa - Shaft power - Puissance sur arbre

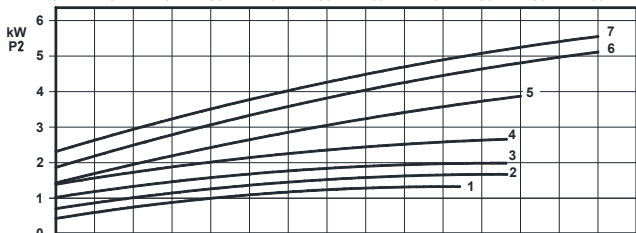

COSTRUZIONE - Materials - Matériaux

Fusioni principali - Principal parts - Parts principal	Ghisa - Cast iron - Fonte - GG 25
Girante - Impeller - Roue	Ghisa - Cast iron - Fonte - GG 25
Albero - Shaft - Arbre	AISI 420
Viteria - Screws - Vis	AISI 304

TENUTE MECCANICHE - Mechanical seals - Garniture mécanique

Doppia tenuta meccanica in bagno d'olio - Double mechanical seals in oil bath - Double garniture mécanique en chambre d'huile	
Tenuta lato motore / tenuta lato liquido : carburo di silicio Motor side / liquid side mechanical seal : silicon carbide	
Garniture mécanique côté du moteur / côté liquide : carbure de silicium	

CARATTERISTICHE TECNICHE - Technical Features - Caractéristiques Techniques

Max. temperatura liquido - Max. liquid temp. - Max. temperature du liquide : 60°C
pH Liquido pompato - pH pumped liquid - pH du liquide pompé : 6 - 10

DIMENSIONI DI INGOMBRO - Dimensions

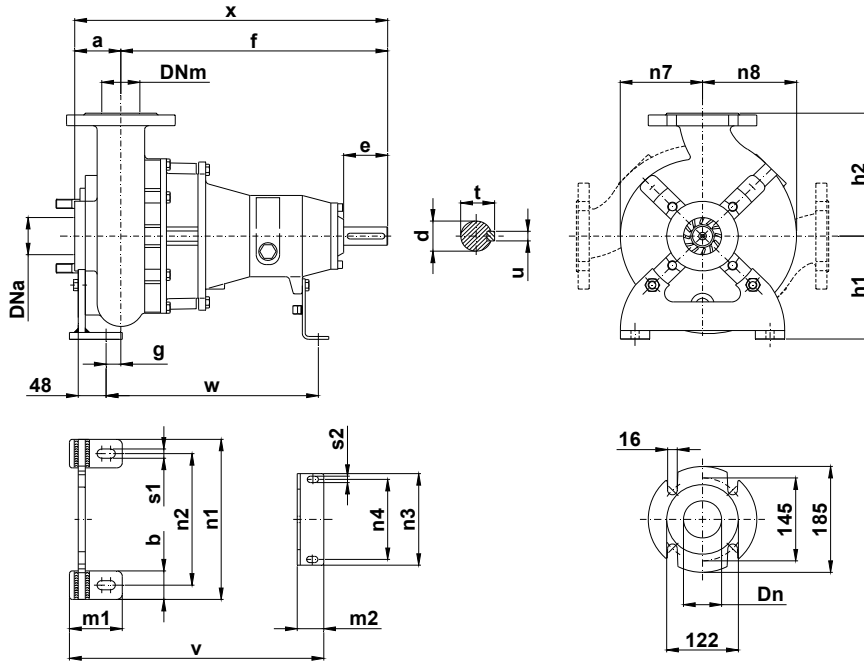

Pompa Pump Pompe	DNa DNm	a	b	c	d	e	f	g	h1	h2	m1	m2	n1	n2	n3	n4	n7	n8	s1	s2	t	u	v	w	x	Peso Weight Poids
KS 65 / .. A1S1 KS 65 / .. A2S1	65	70	50	12	32	80	460	26	180	215	90	45	280	230	120	90	140	160	16	11	35	10	433	360	530	64

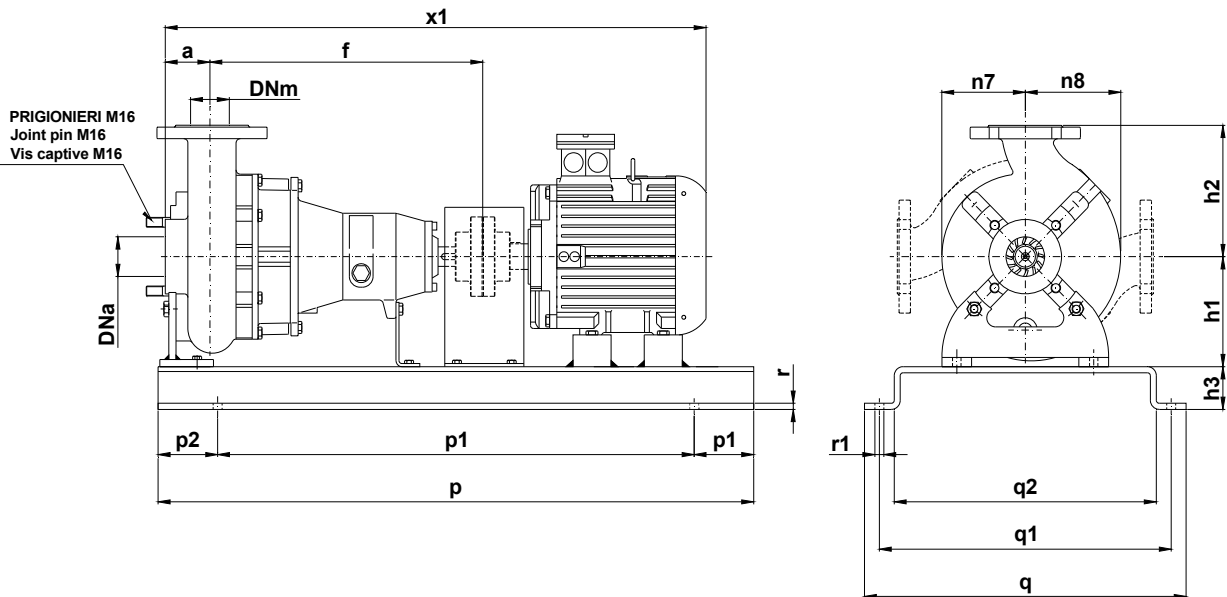

Pompa Pump Pompe	kW	Giri/1', r.p.m.	Motore Motor - Moteur MEC	h3	p	p1	p2	q	q1	q2	r	r1	x1	Peso Weight Poids
KS 65-170B A1 S1	1,5	1450	90	70	1000	800	100	540	490	440	10	16	880	122
KS 65-180B A1 S1	2,2		100										920	130
KS 65-200B A1 S1				3									940	142
KS 65-219B A1 S1													4	940
KS 65-210F A2 S1	5,5		132	90									1200	1000

KS 65/4-220.1.19

Con riserva di variazioni tecniche e costruttive senza preavviso.

With reserve of technical and constructive variations without warning. Avec réserve de variations techniques et constructives sans préavis

POMPE ROTOMEK srl - 20063 CERNUSCO SUL NAVIGLIO (MI) - ITALY - Via Ponchielli, 1

Tel. +39.02.9211.0205 - +39.02.9233.0399 Fax 02.9211.0630 Sito Internet: www.pomperotomek.it E-mail: sales@pomperotomek.it



POMPE ROTOMECC

Elettropompe centrifughe ad asse orizzontale con girante arretrata a vortice
Centrifugal horizontal pumps with vortex impeller
Pompes à axe horizontal avec roue vortex

KS 65/2-220.1

DN 65

Giri/1' - r.p.m.
2900

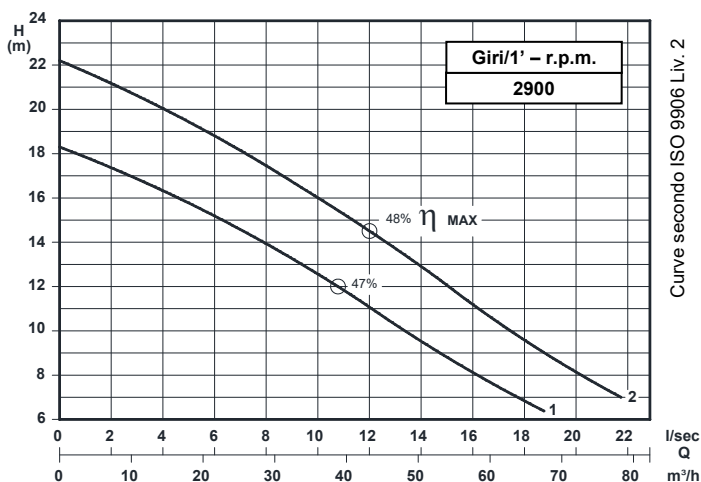

Grandezza - Size - Group 65/220

Curva Curve Courbe N°	Pompa Pump Pompe	DN	Potenza motore Motor power Puissance du moteur P ₂ (Kw)	Giri/1' r.p.m.	Passaggio libero Free passage Section de passage
1	KS 65/2-137K1 A1 S1	65	3	2900	50
2	KS 65/2-150K1 A1 S1		4		

P₂ - Potenza resa - Shaft power - Puissance sur arbre

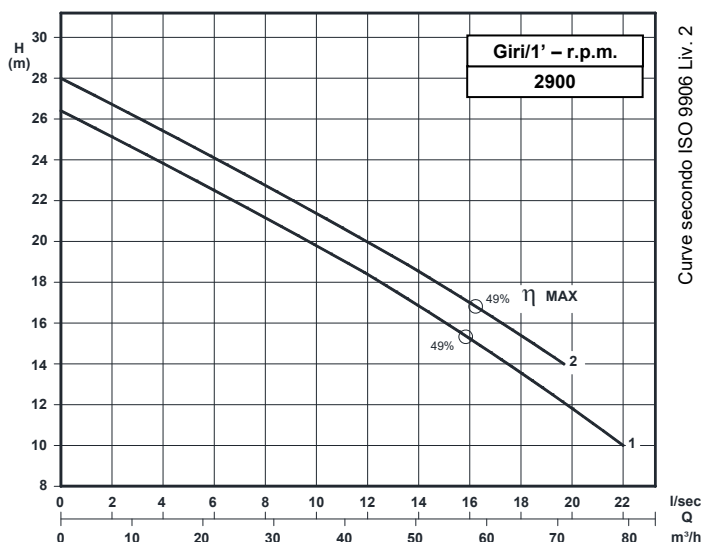
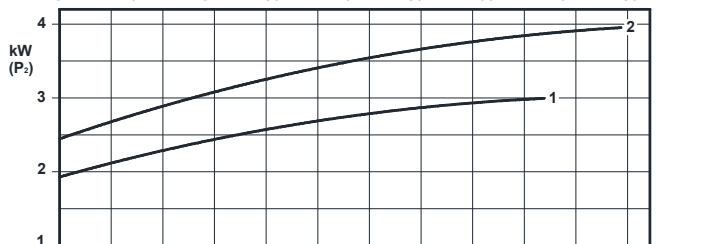

Grandezza - Size - Group 65/220

Curva Curve Courbe N°	Pompa Pump Pompe	DN	Potenza motore Motor power Puissance du moteur P ₂ (Kw)	Giri/1' r.p.m.	Passaggio libero Free passage Section de passage
1	KS 65/2-165K2 A1 S1	65	5,5	2900	45
2	KS 65/2-170K2 A1 S1				

P₂ - Potenza resa - Shaft power - Puissance sur arbre



COSTRUZIONE - Materials - Matériaux	
Fusioni principali - Principal parts - Parts principal	Ghisa - Cast iron - Fonte - GG 25
Girante - Impeller - Roue	Ghisa - Cast iron - Fonte - GG 25
Albero - Shaft - Arbre	AISI 420
Viteria - Screws - Vis	AISI 304

TENUTE MECCANICHE - Mechanical seals - Garniture mécanique
Doppia tenuta meccanica in bagno d'olio - Double mechanical seals in oil bath - Double garniture mécanique en chambre d'huile
Tenuta lato motore / tenuta lato liquido : carburo di silicio Motor side / liquid side mechanical seal : silicon carbide
Garniture mécanique côté du moteur / côté liquide : carbure de silicium

CARATTERISTICHE TECNICHE - Technical Features - Caractéristiques Techniques
Max. temperatura liquido - Max. liquid temp. - Max. temperature du liquide : 60°C
pH Liquido pompato - pH pumped liquid - pH du liquide pompé : 6 - 10

DIMENSIONI DI INGOMBRO – Dimensions

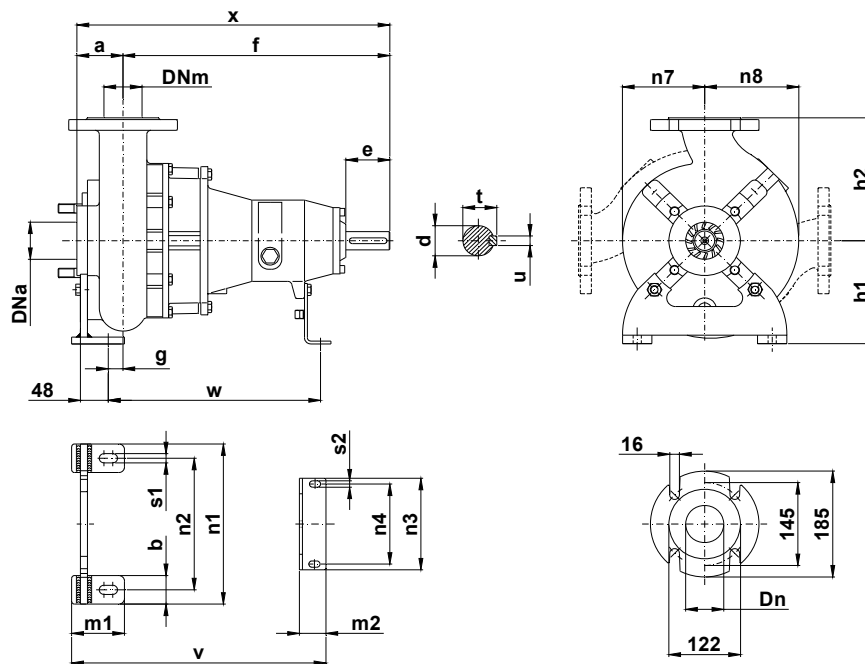

Pompa Pump Pompe	DNa DNm	a	b	c	d	e	f	g	h1	h2	m1	m2	n1	n2	n3	n4	n7	n8	s1	s2	t	u	v	w	x	Peso Weight Poids
KS 65 / .. A1S1	65	70	50	12	32	80	460	26	180	215	90	45	280	230	120	90	140	160	16	11	35	10	433	360	530	64

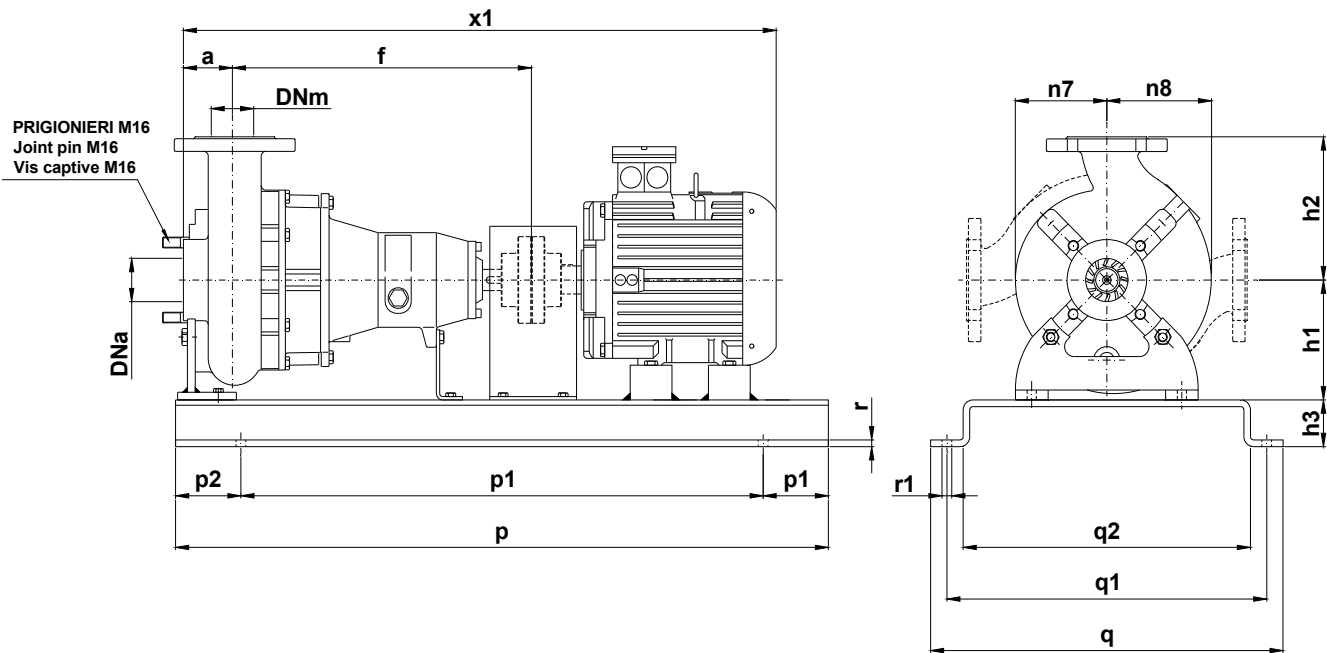

Pompa Pump Pompe	kW	Giri/1' r.p.m.	Motore Motor - Moteur MEC	h3	p	p1	p2	q	q1	q2	r	r1	x1	Peso Weight Poids
KS 65/2-137K1 A1 S1	3	2900	100	70	1000	800	100	540	490	440	10	16	920	128
KS 65/2-150K1 A1 S1	4		112										940	138
KS 65/2-165K2 A1 S1	5,5		132	90	1200	1000	100	560	510	12	18	1050	142	
KS 65/2-170K2 A1 S1														

KS 65/2-220.1.19

Con riserva di variazioni tecniche e costruttive senza preavviso.

With reserve of technical and constructive variations without warning. Avec réserve de variations techniques et constructives sans préavis

POMPE ROTOMECC srl - 20063 CERNUSCO SUL NAVIGLIO (MI) - ITALY - Via Ponchielli, 1

Tel. +39.02.9211.0205 - +39.02.9233.0399 Fax 02 9211.0630 Sito Internet: www.pomperotomec.it E-mail: sales@pomperotomec.it



POMPE ROTOMECC

Elettropompe centrifughe ad asse orizzontale con girante arretrata a vortice
Centrifugal horizontal pumps with vortex impeller
Pompes à axe horizontal avec roue vortex

KS 65/2-220.2

DN 65

Giri/1' - r.p.m.
2900

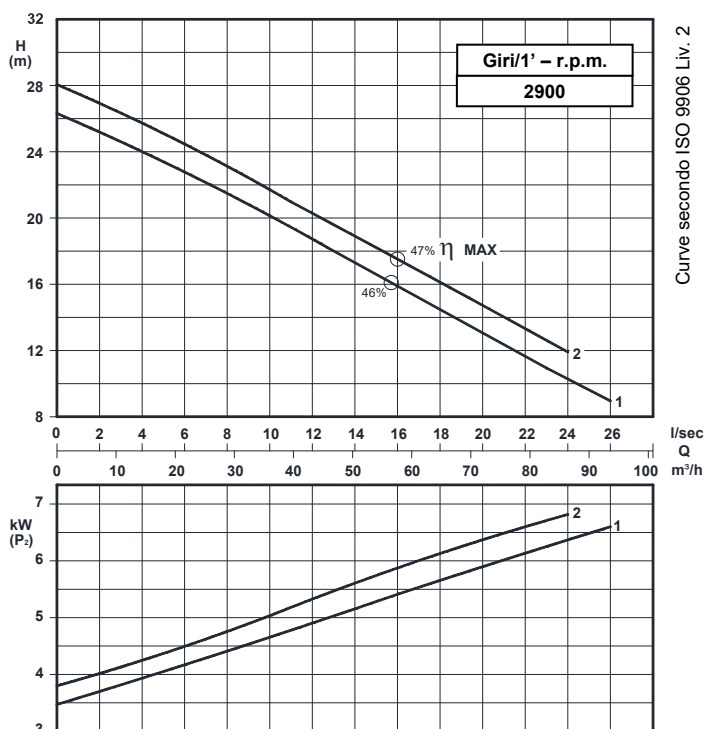

Grandezza - Size - Group 65/220

Curva Curve Courbe N°	POMPA Pump Pompe	DN	Potenza motore Motor power Puissance du moteur P ₂ (Kw)	Giri/1' r.p.m.	PASSAGGIO LIBERO Free passage Section de passage
1	KS 65/2-165K3 A3 S2	65	7,5	2900	50
2	KS 65/2-170K3 A3 S2				

P₂ - Potenza resa - Shaft power - Puissance sur arbre

COSTRUZIONE - Materials - Matériaux

Fusioni principali - Principal parts - Parts principal	Ghisa - Cast iron - Fonte - GG 25
Girante - Impeller - Roue	Ghisa - Cast iron - Fonte - GG 25
Albero - Shaft - Arbre	AISI 420
Viteria - Screws - Vis	AISI 304

TENUTE MECCANICHE - Mechanical seals - Garniture mécanique

Doppia tenuta meccanica in bagno d'olio - Double mechanical seals in oil bath - Double garniture mécanique en chambre d'huile
Tenuta lato motore / tenuta lato liquido : carburo di silicio Motor side / liquid side mechanical seal : silicon carbide Garniture mécanique côté du moteur / côté liquide : carbure de silicium

CARATTERISTICHE TECNICHE - Technical Features - Caractéristiques Techniques

Max. temperatura liquido - Max. liquid temp. - Max. temperature du liquide : 60°C
pH Liquido pompato - pH pumped liquid - pH du liquide pompé : 6 - 10

DIMENSIONI DI INGOMBRO – Dimensions

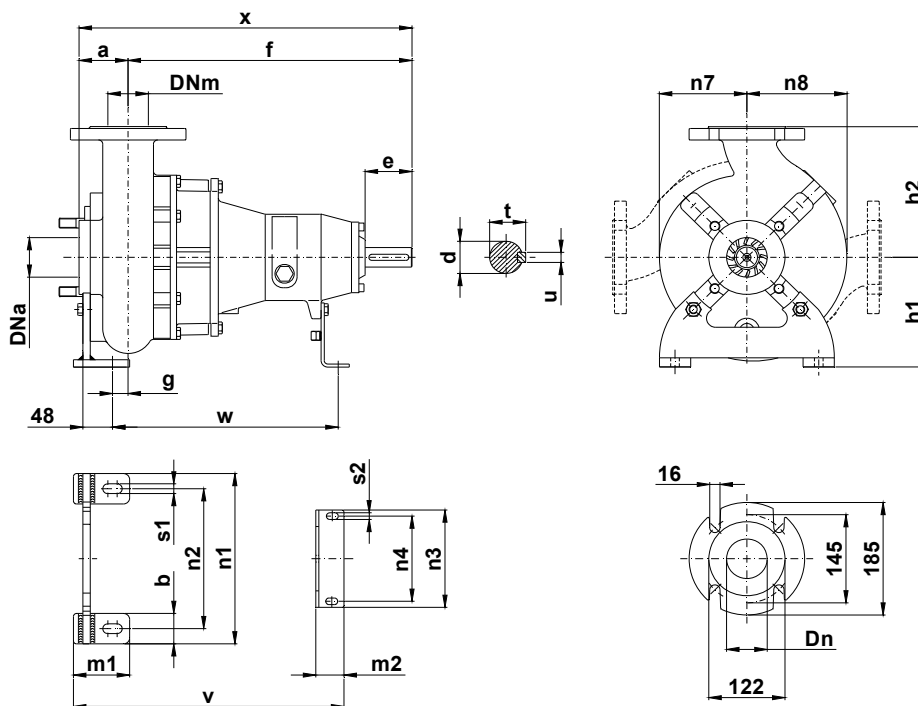

Pompa Pump Pompe	DNa DNm	a	b	c	d	e	f	g	h1	h2	m1	m2	n1	n2	n3	n4	n7	n8	s1	s2	t	u	v	w	x	Peso Weight Poids
KS 65 / .. A3S2	65	70	50	12	42	80	528	27	180	215	90	45	280	230	120	90	140	160	14	11	45	12	496	422	598	85

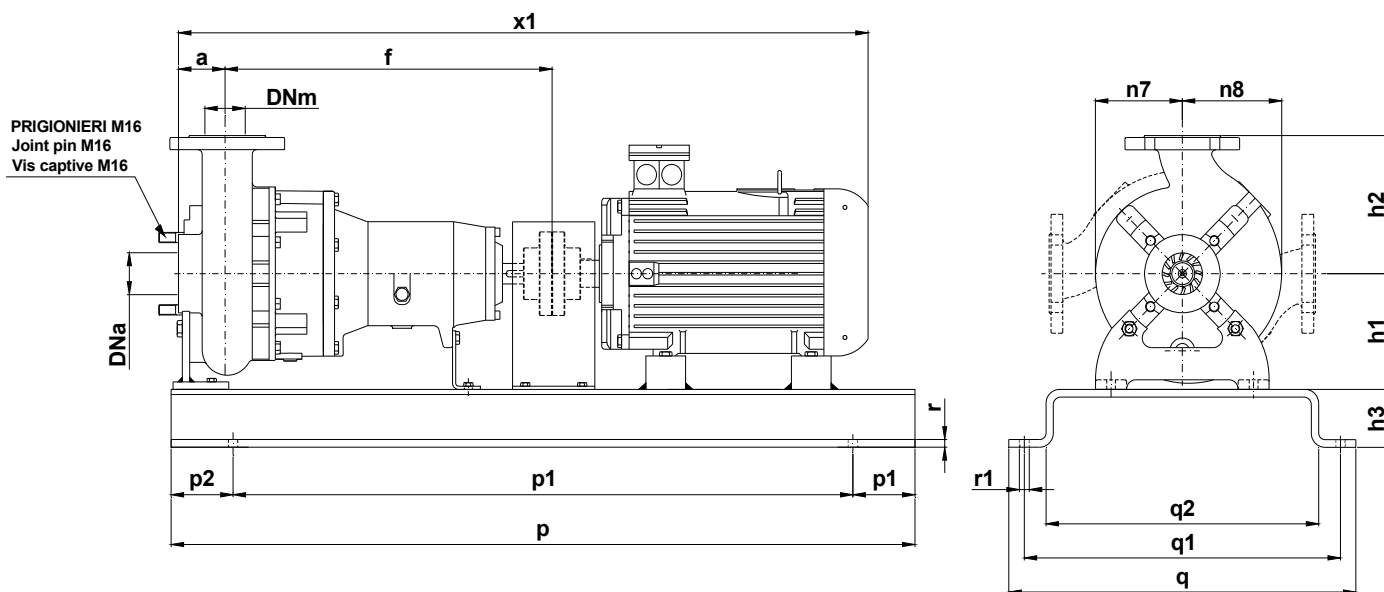

Pompa Pump Pompe	kW	Giri/1' r.p.m.	Motore Motor - Moteur MEC	h3	p	p1	p2	q	q1	q2	r	r1	x1	Peso Weight Poids
KS 65/2-165K2 A3 S2	7,5	2900	132	90	1200	1000	100	560	510	440	12	18	1113	253
KS 65/2-170K3 A3 S2														

KS 65/2-220.1.19

Con riserva di variazioni tecniche e costruttive senza preavviso.

With reserve of technical and constructive variations without warning. Avec réserve de variations techniques et constructives sans préavis

POMPE ROTOMEK srl - 20063 CERNUSCO SUL NAVIGLIO (MI) - ITALY - Via Ponchielli, 1

Tel. +39.02.9211.0205 - +39.02.9233.0399 Fax 02 9211.0630 Sito Internet: www.pomperotomec.it E-mail: sales@pomperotomec.it



POMPE ROTOMECC

Elettropompe centrifughe ad asse orizzontale con girante arretrata a vortice
Centrifugal horizontal pumps with vortex impeller
Pompes à axe horizontal avec roue vortex

KS 65/2-220.3

DN 65

Giri/1' - r.p.m.
2900

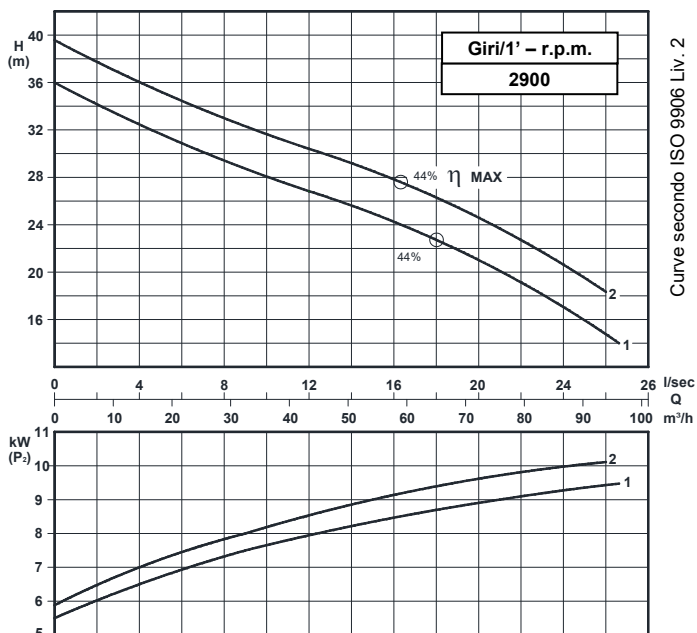

Grandezza - Size - Group 65/220

Curva Curve Courbe N°	Pompa Pump Pompe	DN	Potenza motore Motor power Puissance du moteur P2 (Kw)	Giri/1' r.p.m.	Passaggio libero Free passage Section de passage
1	KS 65/2-175 A3 S2	65	11	2900	45
2	KS 65/2-185 A3 S2				

P2 - Potenza resa - Shaft power - Puissance sur arbre

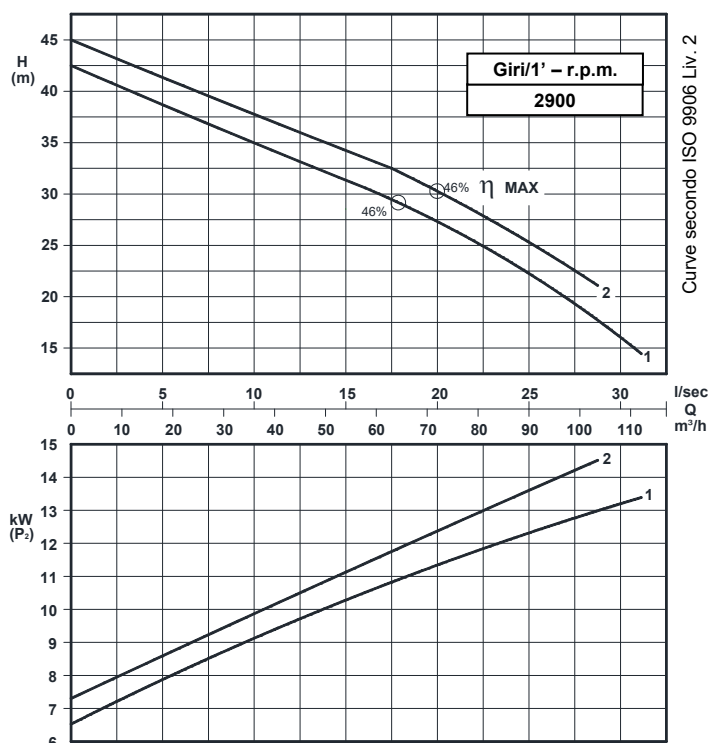

COSTRUZIONE - Materials - Matériaux	
Fusioni principali - Principal parts - Parts principal	Ghisa - Cast iron - Fonte - GG 25
Girante - Impeller - Roue	Ghisa - Cast iron - Fonte - GG 25
Albero - Shaft - Arbre	AISI 420
Viteria - Screws - Vis	AISI 304

TENUTE MECCANICHE - Mechanical seals - Garniture mécanique
Doppia tenuta meccanica in bagno d'olio - Double mechanical seals in oil bath - Double garniture mécanique en chambre d'huile
Tenuta lato motore / tenuta lato liquido : carburo di silicio Motor side / liquid side mechanical seal : silicon carbide
Garniture mécanique côté du moteur / côté liquide : carbure de silicium

CARATTERISTICHE TECNICHE - Technical Features - Caractéristiques Techniques
Max. temperatura liquido - Max. liquid temp. - Max. temperature du liquide : 60°C
pH Liquido pompato - pH pumped liquid - pH du liquide pompé : 6 - 10

Grandezza - Size - Group 65/220

Curva Curve Courbe N°	Pompa Pump Pompe	DN	Potenza motore Motor power Puissance du moteur P2 (Kw)	Giri/1' r.p.m.	Passaggio libero Free passage Section de passage
1	KS 65/2-195 A3 S2	65	15	2900	45
2	KS 65/2-205 A3 S2				

P2 - Potenza resa - Shaft power - Puissance sur arbre

DIMENSIONI DI INGOMBRO – Dimensions

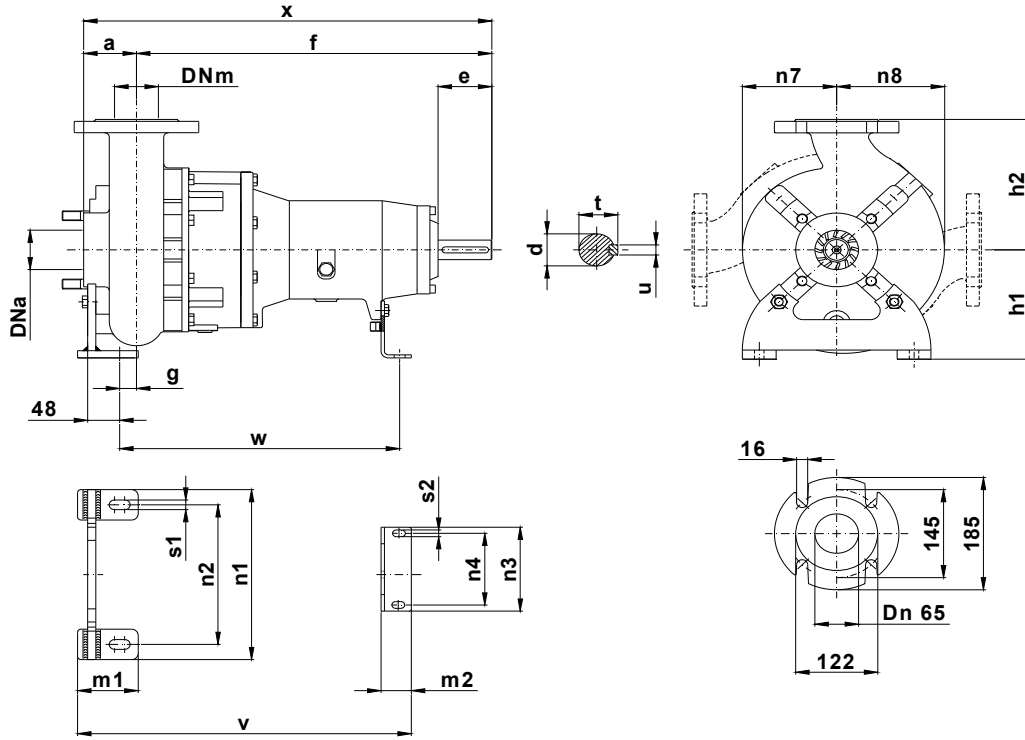

Pompa Pump Pompe	DNa DNm	a	b	c	d	e	f	g	h1	h2	m1	m2	n1	n2	n3	n4	n7	n8	s1	s2	t	u	v	w	x	Peso Weight Poids
KS 65 / .. A3S2	65	70	50	12	42	80	528	27	180	215	90	45	280	230	120	90	140	160	14	11	45	12	496	422	598	85

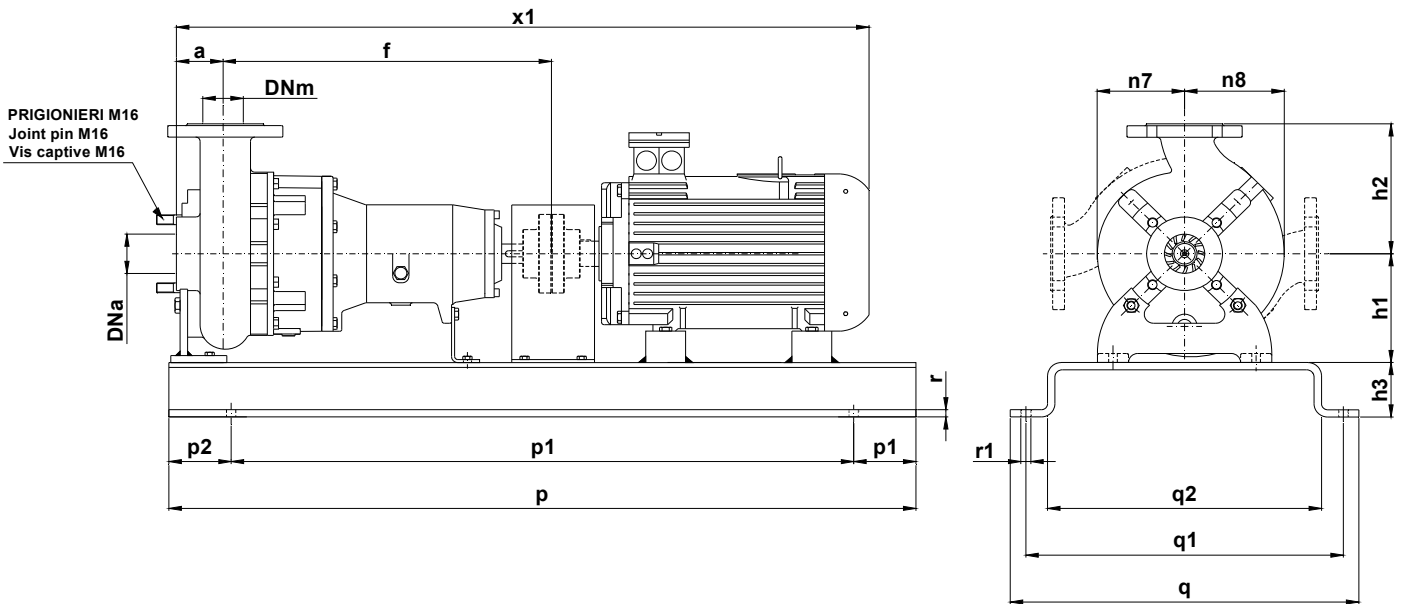

Pompa Pump Pompe	kW	Giri/1' r.p.m.	Motore Motor - Moteur MEC	h3	p	p1	p2	q	q1	q2	r	r1	x1	Peso Weight Poids
KS 65/2-175 A3 S2	11	2900	160	90	1200	1150	100	540	490	440	12	18	1210	305
KS 65/2-185 A3 S2														
KS 65/2-195 A3 S2	15	2900	160	90	1200	1150	100	540	490	440	12	18	1210	315
KS 65/2-205 A3 S2														

KS 65/2-220.3.19

Con riserva di variazioni tecniche e costruttive senza preavviso.

With reserve of technical and constructive variations without warning. Avec réserve de variations techniques et constructives sans préavis

POMPE ROTOMECH srl - 20063 CERNUSCO SUL NAVIGLIO (MI) - ITALY - Via Ponchielli, 1

Tel. +39.02.9211.0205 - +39.02.9233.0399 Fax 02 9211.0630 Sito Internet: www.pomperotomec.it E-mail: sales@pomperotomec.it